

Service

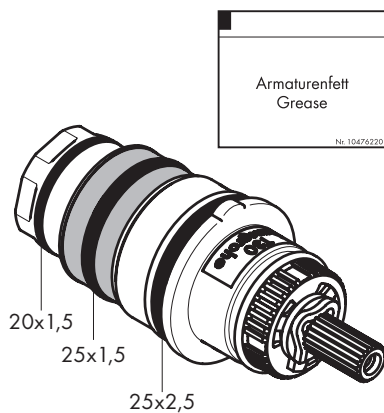

98282000

hansgrohe



Symbolerklärung



Einjustieren

Nach erfolgter Montage muss die Auslauftemperatur des Thermostaten überprüft werden. Eine Korrektur ist erforderlich wenn die an der Entnahmestelle gemessene Temperatur von der am Thermostaten eingestellten Temperatur abweicht.

max.
≈ 42 °C

Safety Function

Dank der Safety Function lässt sich die gewünschte Höchsttemperatur von z. B. max. 42 °C voreinstellen.



Bedienung

Um die Leichtigkeit der Regeleinheit zu gewährleisten, sollte der Thermostat von Zeit zu Zeit auf ganz warm und ganz kalt gestellt werden.



Montage (siehe Seite 10)

English

Description du symbole



Réglage

Le montage terminé, contrôler la température de l'eau puisée au mitigeur thermostatique. Un étalonnage est nécessaire si la température de l'eau mitigée mesurée au point de puisage diffère sensiblement de celle affichée sur le thermostat.

max.
≈ 42 °C

Safety Function

Grâce à la fonction Safety, il est possible de pré-régler la température maximale par exemple max. 42 °C souhaitée.



Instructions de service

Pour assurer le mouvement facile de l'élément thermostatique, le thermostat devrait être placé de temps en temps en position très chaude et très froide.



Montage (voir pages 10)

Italiano

Symbol description



Adjustment

After the installation, the output temperature of the thermostat must be checked. A correction is necessary if the temperature measured at the output differs from the temperature set on the thermostat.

max.
≈ 42 °C

Safety Function

The desired maximum temperature for example max. 42 °C can be pre-set thanks to the safety function.



Operation

To guarantee the smooth running of the thermostat, it is necessary from time to time to turn the thermostat from total hot to total cold.



Assembly (see page 10)

Descrizione simbolo



Taratura

Effettuata l'installazione del miscelatore termostatico bisogna controllare la temperatura di uscita. La taratura è necessaria quando la temperatura dell'acqua misurata sul punto di prelievo non corrisponde a quella fissata sul termostato.

max.
≈ 42 °C

Safety Function

Grazie alla funzione anticottature Safety la temperatura massima per esempio max. 42 °C desiderata è facilmente regolabile.



Procedura

Per garantire la scorrevolezza dell'elemento di regolazione, di tanto in tanto si dovrebbe regolare il termostatico passando da tutto caldo a tutto freddo.



Montaggio (vedi pagg. 10)

**Descripción de símbolos****Puesta a punto**

Después del montaje deberá comprobarse la temperatura del agua del termostato, en la salida del caño. Una corrección se efectuará siempre y cuando la temperatura del agua tomada a la salida del caño, no corresponda con la indicada en el volante del termostato.

max.
≈ 42 °C

Safety Function

Gracias al tope de temperatura se puede graduar la temperatura máxima por ejemplo max. 42° C.

**Manejo**

Para garantizar el funcionamiento duradero del termostato, el mando del mismo debería girarse de vez en cuando del extremo frío al extremo caliente.

**Montaje** (ver página 10)**Dansk****Symbolbeschrijving****Correctie**

Na montage dient de uitstroomtemperatuur van de thermostaat gecontroleerd te worden. Een correctie is noodzakelijk als de aan het tappunt gemeten temperatuur afwijkt van de op de thermostaat ingestelde temperatuur.

max.
≈ 42 °C

Safety Function

Dankzij de Safety Function kan de gewenste maximale temperatuur van bijv. max. 42° C van te voren worden ingesteld.

**Bediening**

Om het soepel lopen van de regelenheid te garanderen moet de thermostaat van tijd tot tijd op heel koud en heel warm worden ingesteld.

**Montage** (zie blz. 10)**Português****Symbolbeskrivelse****Justering**

Efter monteringen skal termostatens udløbstemperatur kontrolleres. Såfremt den målte vandtemperatur afviger fra den på termostaten viste forindstilling er en korrigerig af skalagrebet nødvendig.

max.
≈ 42 °C

Safety Function

Takket være Safety varmtvandsbegrænsningen kan maksimaltemperaturen forudindstilles eksempel max. 42° C.

**Brugsanvisning**

For at sikre optimal funktion af termostaten, bør termostaten fra tid til anden motioneres (stilles skiftevis helt varm og helt kold).

**Montering** (se s. 10)**Descrição do símbolo****Afinção**

É necessária correção se a temperatura medida no ponto de saída diferir da temperatura marcada na escala.

max.
≈ 42 °C

Safety Function

Graças à função de segurança pode-se regular a temperatura máxima por exemplo max. 42°C.

**Funcionamento**

Para garantir um funcionamento suave do elemento termostático é necessário de vez em quando rodar totalmente o manípulo da termostática da posição quente para a fria.

**Montagem** (ver página 10)



Opis symbolu



Regulacja

Po ukończeniu montażu należy sprawdzić temperaturę ciepłej wody na wylocie z termostatu. Korekta będzie konieczna wtedy, gdy zmierzona temperatura na wylocie różni się od temperatury ustawionej na termostacie.

max. Safety Function

≈ 42 °C Dzięki funkcji zabezpieczającej można przestawić żądaną maksymalną temperaturę np. na maks. 42°C.



Obsługa

Aby zachować łatwość obsługi termostatu, od czasu do czasu należy go przekręcić na całkiem zimną i na całkiem ciepłą wodę.



Montaż (patrz strona 10)

Slovensky

Popis symbolů



Nastavení

Po ukončení montáže se musí zkontrolovat teplota vody vytékající z termostatu. Pokud se teplota změřená v místě odběru liší od teploty nastavené na termostatu, je nutné provést korekci.

max. Safety Function

≈ 42 °C Díky Safety Function je možné předem nastavit nejvyšší požadovanou teplotu, např. max. 42°C.



Ovládání

Aby byl zajištěn lehký chod regulační jednotky, měl by se termostat čas od času nastavit na úplně horkou a úplně studenou vodu.



Montáž (viz strana 10)

中文

Popis symbolov



Nastavenie

Po ukončení montáže sa musí skontrolovať teplota vody vytekajúcej z termostatu. Pokiaľ sa teplota nameraná na mieste odberu líši od teploty nastavenej na termostate, je nutné vykonať korekciu.

max. Safety Function

≈ 42 °C Vďaka Safety Function je možné vopred nastaviť najvyššiu požadovanú teplotu, napr. max. 42°C.



Obsluha

Aby bol zaistený ľahký chod regulačnej jednotky, mal by sa termostat z času čas nastaviť na maximálne horúcu a maximálne studenú vodu.



Montáž (viď strana 10)

符号说明



校准

安装完成后必须检查调温器的出水温度。如在取水处测量所得的温度与调温器上设定的温度有偏差，那么必须进行调整。

max. 安全功能

≈ 42 °C 恒温阀芯的安全功能可以预先设定所希望的最高出水温度，例如最高温度为42℃



操作

为了保证恒温器的稳定运转，请务必定期从最热到最冷转动调温器。



安装 (参见第页 10)



Описание символов



Настройка

После монтажа следует проверить температуру на выходе из термостата. Скорректируйте температуру воды, если она отличается от установленной на термостате.

max. Safety Function

≈ 42 °C С помощью функции Safety Function может быть задана максимальная температура воды, например 42 °C.



Эксплуатация

Для гарантии плавного изменения температуры и долгого срока службы необходимо периодически поворачивать ручку регулировки температуры из положение максимально горячая в положение максимально холодная вода.



Монтаж (см. стр. 10)

Suomi

Szimbólumok leírása



Beszerezés

A sikeres felszerelést követően ellenőrizni kell a termosztát kifolyási hőmérsékletét. Helyesbítés szükséges, ha a vízkivétel helyén mért hőmérséklet eltér a termosztáton beállított hőmérséklettől.

max. Safety Function (Biztonsági

≈ 42 °C funkció)

A biztonsági funkciónak köszönhetően a kívánt hőmérsékletet pl. 42 Celsius fokban maximálhatjuk.



Használat

Ahhoz, hogy a szabályozóegység jól működjön, a termosztátot időről időre teljesen melegre és teljesen hidegre kell állítani.



Szerelés (lásd a oldalon 10)

Svenska

Merkin kuvaus



Säätö

Asennuksen jälkeen termostaatin ulostulolämpötila on tarkastettava. Säätö on tarpeen, jos käyttöpisteessä mitattu veden lämpötila eroaa termostaattiin säädetyistä lämpötilasta.

max. Safety Function

≈ 42 °C Safety Function:ista johtuen haluttu maksimilämpötila voidaan esiasettaa, esimerkiksi maks. 42 °C.



Käyttö

Säätöyksikön kevytkäyttöisyyden takaamiseksi, säädä säätöyksikkö ajoittain täysin kylmälle ja täysin kuumalle.



Asennus (katso sivu 10)

Symbolförklaring



Inställning av maxtemperatur

När monteringen är klar måste termostatens tömningstemperatur kontrolleras. En justering är nödvändig om den uppmätta temperaturen vid tappningsstället avviker från den som är inställd på termostaten.

max. Safety Function

≈ 42 °C Med hjälp av Safety Function kan du ställa in den önskade maximaltemperaturen till exempelvis 42°C och så förhindra skällningsrisk för barn.



Hantering

För att garantera att termostaten ej kalkar igen, ska den regelbundet, en gång per vecka, konditioneras. Det sker genom att man några gånger snabbt slås om temperaturen från hett till kallt och tillbaka.



Montering (se sidan 10)



Simbolio aprašymas



Nustatymas

Sumontavus, būtina patikrinti vandens, išeinančio iš termostato, temperatūrą. Pakoreguokite vandens temperatūrą, jei būtina.

max. Apsaugos funkcija

≈ 42 °C "Safety" funkcija karšto vandens temperatūra gali būti iš anksto ribota iki, pvz., ne aukštesnės kaip 42° C.



Eksploatacija

Tam, kad būtų garantuotas tolygus temperatūros reguliavimas ir ilgas naudojimasis, būtina periodiškai temperatūros rankenėlę pasukti į karščiausios ir šalčiausios temperatūros padėtį.



Montavimas (žr. psl. 10)

Türkçe

Opis simbola



Regulacija

Nakon instalacije treba ispitati izlaznu temperaturu termostata. Korekcija je neophodna, ako izmjerena temperatura na mjestu uzimanja odstupa od temperature koja je namještena na termostatu.

max. Safety Funkcija

≈ 42 °C Zahvaljujuću Safety funkciji može se podesiti željena maksimalna temperatura, npr. i 42° C



Upotreba

Kako bi se olakšala prohodnost i produljio vijek trajanja regulacijske jedinice, potrebno je s vremena na vrijeme podesiti termostat iz položaja maksimalno tople u položaj maksimalno hladne vode.



Sastavljanje (pogledaj stranicu 10)

Română

Simge açıklaması



Ayarlama

Montaj tamamlandıktan sonra, termostatların çıkış sıcaklığı kontrol edilmelidir. Alma noktasında ölçülen sıcaklık termostatta ayarlanan sıcaklıktan farklıysa, bir düzeltme gereklidir.

max. Safety Function

≈ 42 °C Emniyet fonksiyonu sayesinde, istenen maksimum sıcaklık Örn; maks. 42° C önceden ayarlanabilir.



Kullanımı

Ayar ünitesinin kolay hareket etmesini sağlamak için, termostat belirli aralıklarla tamamen sıcak ve soğuk konuma getirilmelidir.



Montajı (bakınız sayfa 10)

Descrierea simbolurilor



Reglare

După montare verificați temperatura de ieșire la termostat. În cazul în care există o diferență între temperatura măsurată la golițe și temperatura reglată la termostat trebuie efectuată o corecție.

max. Funcția de siguranță

≈ 42 °C Datorită funcției de siguranță puteți pregăti temperatura maximă, de ex. 42° C.



Utilizare

Pentru garantarea mișcării ușoare a unității de reglare, vă recomandăm să setați termostatul pe pozițiile limită cald și rece.



Montare (vezi pag. 10)

**Περιγραφή συμβόλων****Ρύθμιση**

Αφότου πραγματοποιηθεί η συναρμολόγηση, θα πρέπει να ελεγχθεί η θερμοκρασία του στομίου εκροής του θερμοστάτη. Μία διόρθωση είναι απαραίτητη όταν η μετρούμενη στο σημείο λήψης θερμοκρασία αποκλίνει από τη ρυθμισμένη στο θερμοστάτη θερμοκρασία.

max. Safety Function (Λειτουργία ασφαλείας)

≈ 42 °C

Χάρη στη λειτουργία ασφαλείας Safety Function, είναι δυνατή η προρρύθμιση της επιθυμητής μέγιστης θερμοκρασίας (π.χ. 42° C).

**Χειρισμός**

Για να διασφαλίσετε την καλή λειτουργία της μονάδας ρύθμισης, θα πρέπει να ρυθμίζετε το θερμοστάτη από καιρού εις καιρόν σε εντελώς ζεστό ή εντελώς κρύο.



Συναρμολόγηση (βλ. Σελίδα 10)

Estonia**Opis simbola****Nastavitev**

Po opravljeni montaži je treba preveriti iztočno temperaturo na termostatu. Če na odzmemnem mestu izmerjena temperatura odstopa od temperature, nastavljene na termostatu, je potreben popravek.

max. Varnostna funkcija

≈ 42 °C

Varnostna funkcija omogoča, da vnaprej nastavimo najnižjo želeno temperaturo npr. 42° C.

**Upravljanje**

Da bi zagotovili gladko delovanje enote za uravnavanje, je potrebno termostat občasno nastaviti popolnoma na toplo in popolnoma na mrzlo.



Montaža (glejte stran 10)

Latvian**Sümbolite kirjeldus****Reguleerimine**

Paigaldamise järel tuleb kontrollida termostaadi väljundtemperatuuri. Kui väljavoolu kohas mõõdetud temperatuur erineb termostaadiga sisestatust, tuleb seda reguleerida.

max. Turvafunktsioon

≈ 42 °C

Tänu ohutusfunktsioonile on võimalik soovitud maksimaaltemperatuuri eelnevalt sisestada (nt maks. 42 °C).

**Kasutamine**

Termostaadi hea toimimise tagamiseks on tarvis termostaat keerata aeg-ajalt päris kuuma ja päris külma peale.



Paigaldamine (vt lk 10)

Simbolu nozīme**Ieregulēšana**

Pēc montāžas jāpārbauda termostata iztekas temperatūra. Korektūra ir nepieciešama gadījumā, ja temperatūra iztekas vietā atšķiras no termostatā iestatītās temperatūras.

max. Drošības funkcija

≈ 42 °C

Pateicoties drošības funkcijai, vēlamo augstāko temperatūru, piem., maks. 42° C, var iestatīt jau iepriekš.

**Lietošana**

Lai nodrošinātu regulatora nevainojamu darbību, termostatu laiku pa laikam jāiestata uz maksimāli aukstu un maksimāli karstu ūdeni.



Montāža (skat. lpp. 10)



Opis simbola



Podešavanje

Nakon instalacije potrebno je ispitati izlaznu temperaturu termostata. Korekcija je neophodna, ako izmerena temperatura odstupa od temperature koja je nameštena na termostatu.

max. Safety funkcija

≈ 42 °C Zahvaljujuću Safety funkciji, može se podesiti željena maksimalna temperatura, npr. maks. 42° C.



Rukovanje

Kako bi se olakšala prohodnost i produžio vek trajanja regulacione jedinice, potrebno je s vremena na vreme podesiti termostat na položaje za maksimalno toplu i maksimalno hladnu vode.



Montaža (vidi stranu 10)

БЪЛГАРСКИ

Symbolbeskrivelse



Justering

Efter avsluttet montering skal termostaten utløpstemperatur kontrolleres. Det er nødvendig med korrektur når temperaturen målt ved uttaksstedet avviker fra temperaturen som er innstilt på termostaten.

max. Safety Function

≈ 42 °C Takket være egenskapen "Safety Function" kan det forhåndsinnstilles en ønsket maks. temperatur, f.eks. 42 °C.



Betjening

For å holde regulerings-enheten bevegelig, skal termostaten stilles fra tid til annen på helt varmt og helt kaldt.



Montasje (se side 10)

Shqip

Описание на символите



Юстиране

След извършен монтаж трябва да се провери температурата на крайника на термостата. Ако измерената температура на мястото на водоземане се различава от настроената на термостата температура, е необходима корекция.

Safety Function (Функция за безопасност)

max. ≈ 42 °C Благодарение на Safety Function (функция за безопасност) желаната максимална температура може да се настрои предварително напр. на макс. 42 °C.



Обслужване

За да се гарантира лекоподвижността на регулиращото звено, от време на време термостатът трябва да се поставя на максимално топло и на максимално студено.



Монтаж (вижте стр. 10)

Përshkrimi i simbolit



Justimi

Pas montimit duhet kontrolluar temperatura në dalje e termostatit. Korrigjimet janë të nevojshme, nëse temperatura e matur në pikën e rrjedhjes së ujit nuk është e njëjtë me temperaturën e përcaktuar në termostat.

max. ≈ 42 °C Falë Safety Function mund të përcaktohet temperatura maksimale e dëshiruar, p.sh. 42 °C.



Përdorimi

Për të lehtësuar përdorimin e njësisë rregulluese, termostati do të duhej çuar herë pas here nga shumë i ngrohtë në shumë të ftohtë.



Montimi (shih faqen 10)



وصف الرمز

الضبط



بعد التركيب يجب فحص درجة حرارة الترموستات.
يلزم إجراء تصحيح إذا اختلفت درجة الحرارة المقاسة
عند موقع القياس عن درجة حرارة الترموستات.

وظيفة الأمان max.

يمكن إجراء ضبط مسبق للحد الأقصى لدرجة الحرارة
المرغوبة، على سبيل المثال بحد أقصى 42° بفضل
وظيفة الأمان.

التشغيل



لضمان التشغيل السلس للترموستات، من الضروري
تحويله من وقت إلى آخر من أقصى السخونة إلى
أقصى البرودة.

التركيب (راجع صفحة 10)



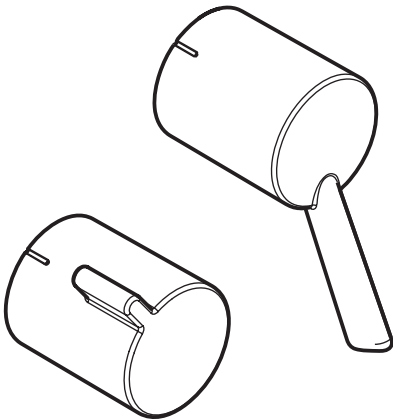
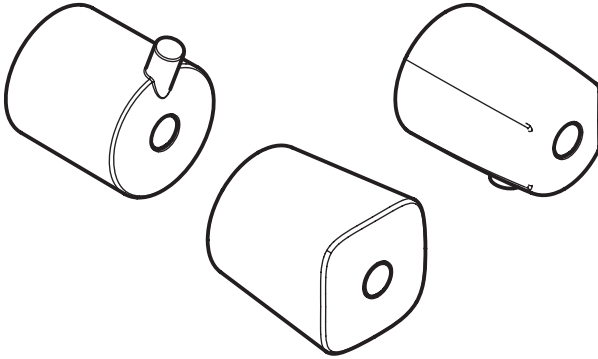
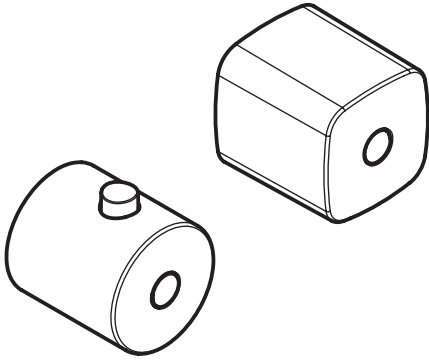

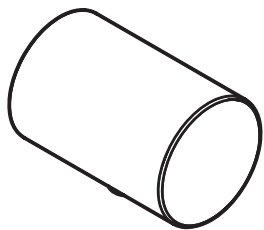

18

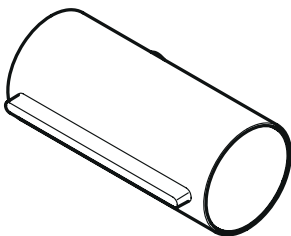

20

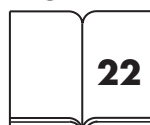
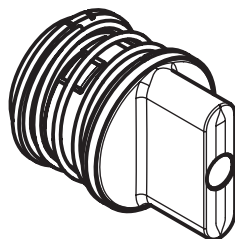

22

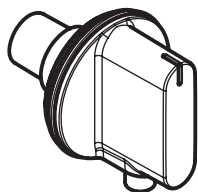

26

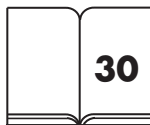

30

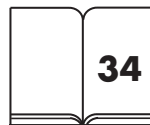
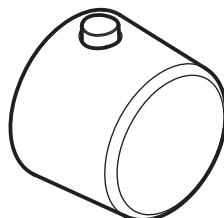

34

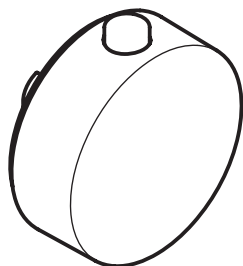

38

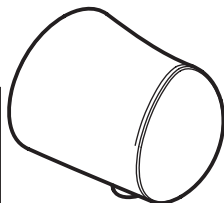

42

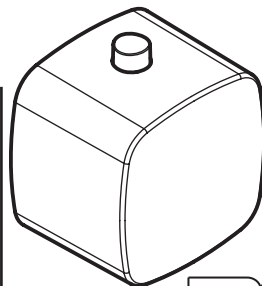

44

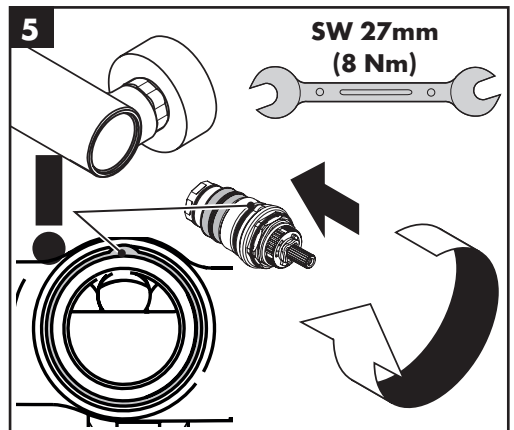
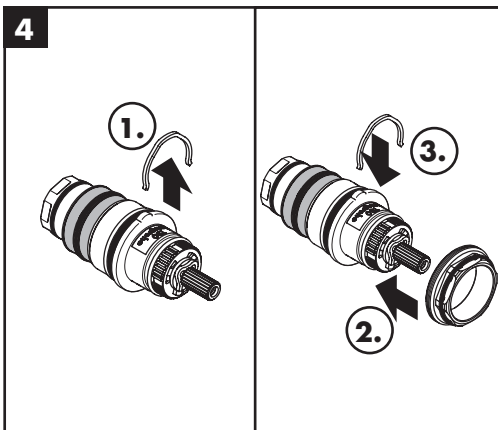
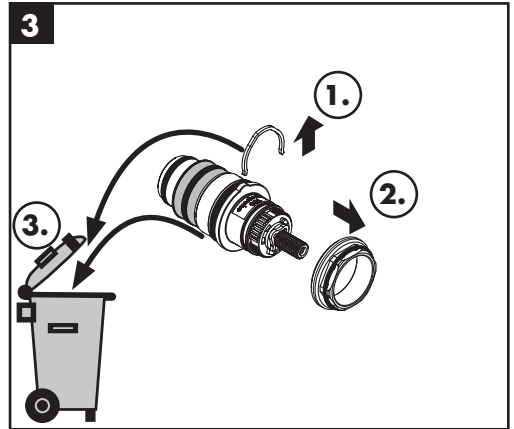
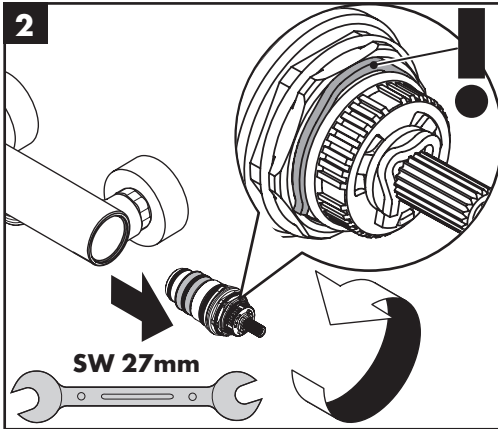
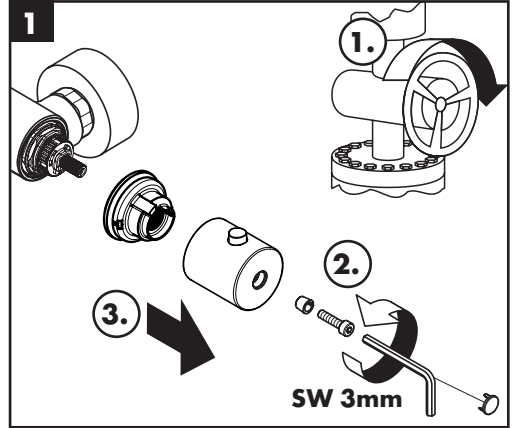
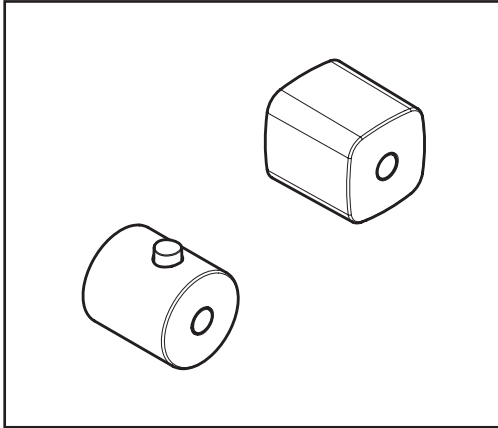

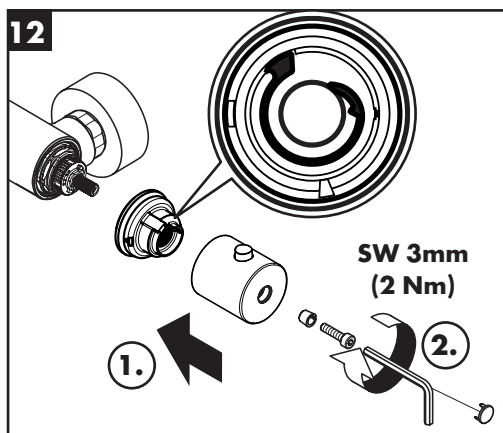
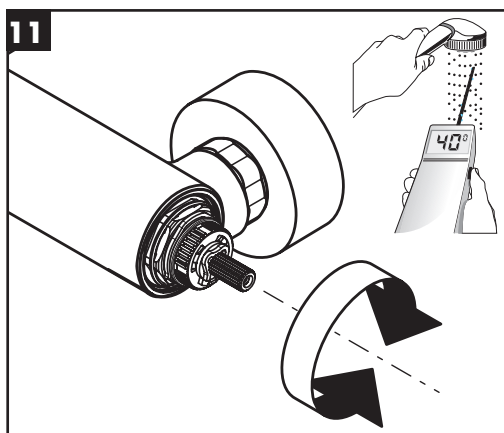
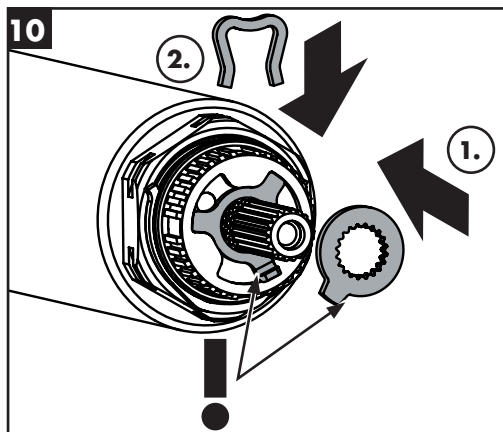
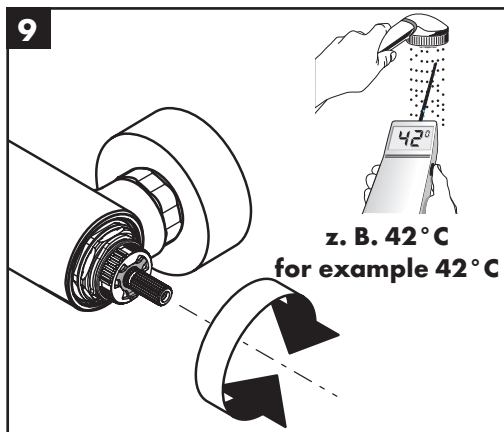
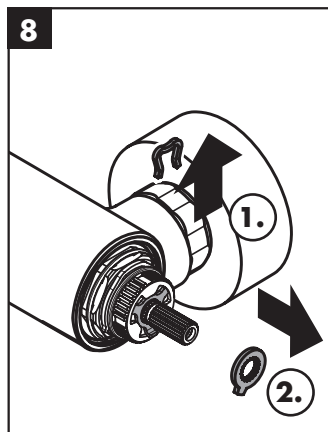
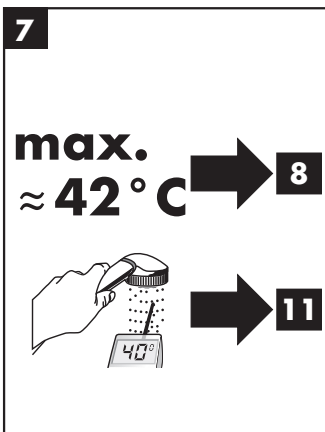
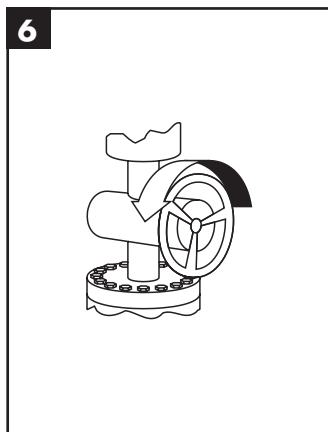

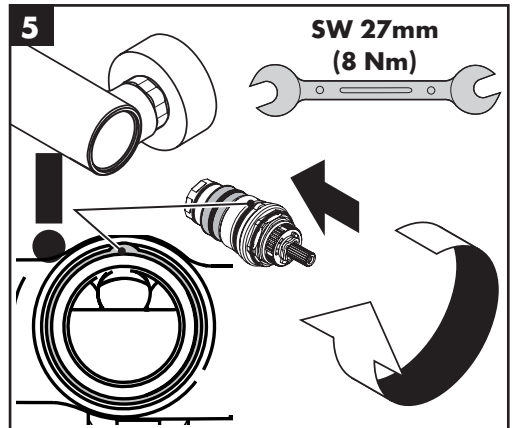
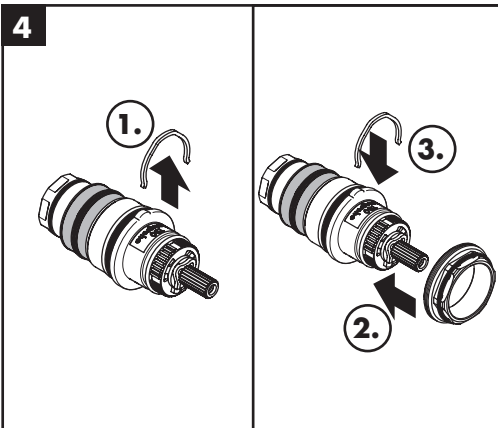
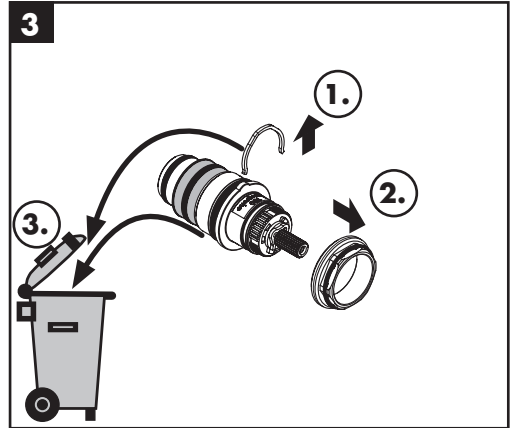
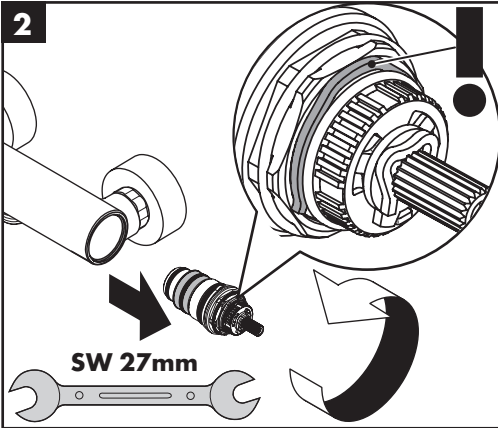
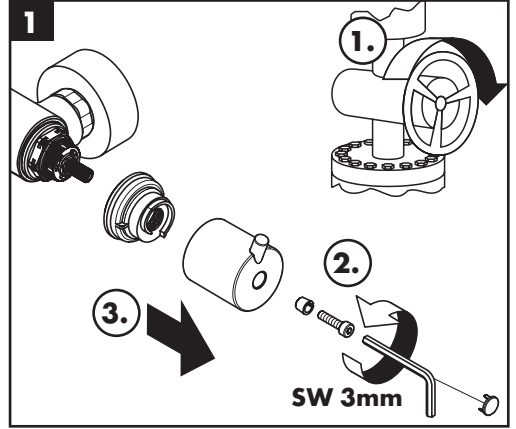
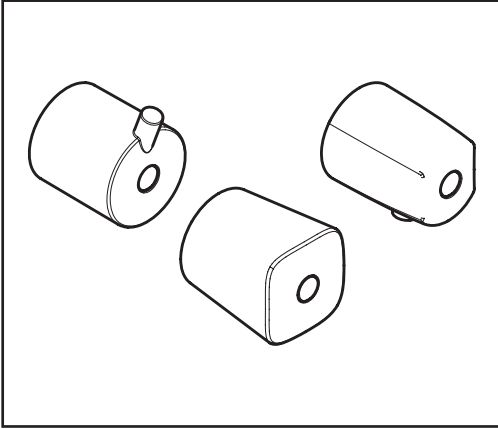

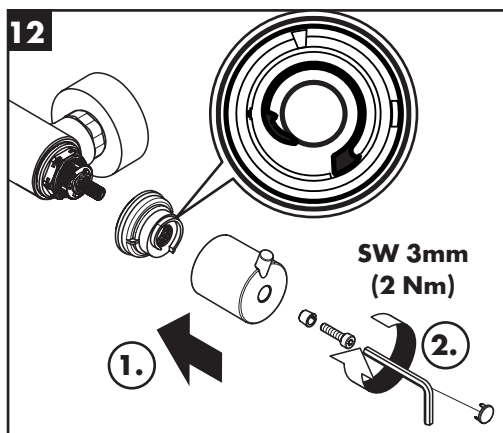
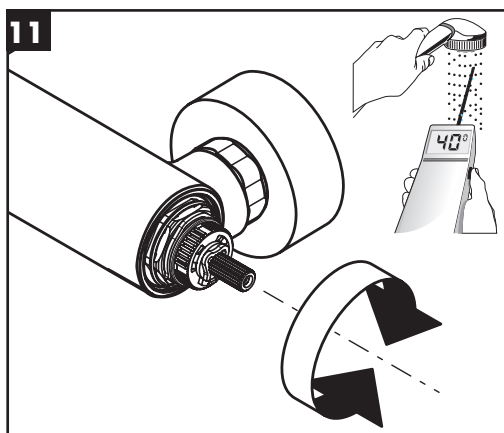
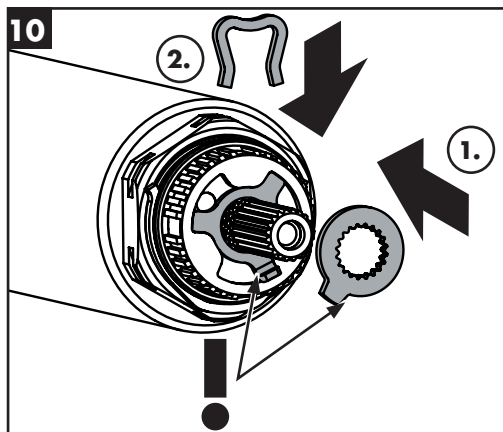
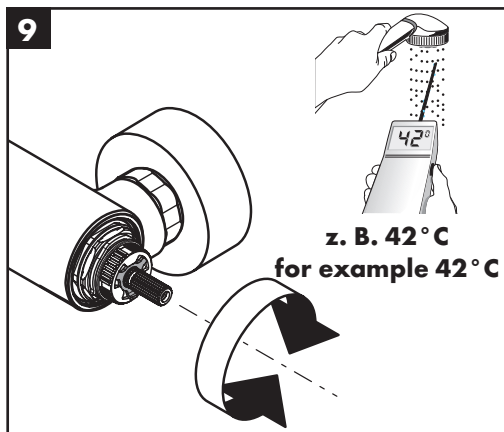
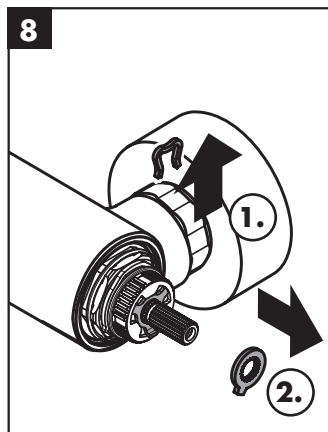
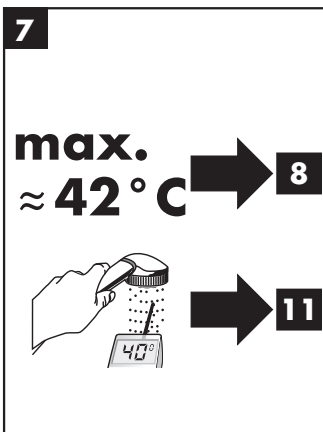
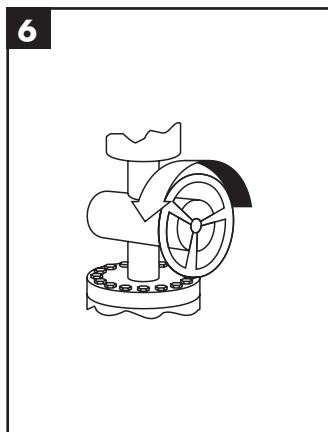

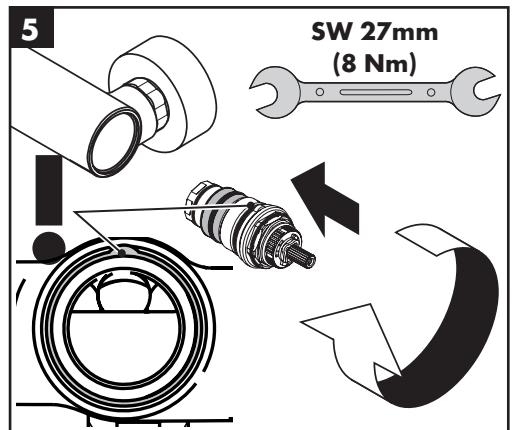
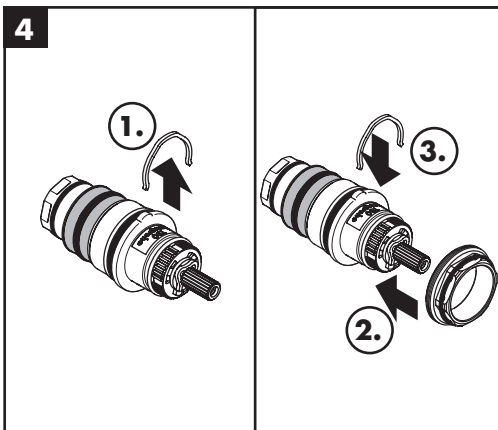
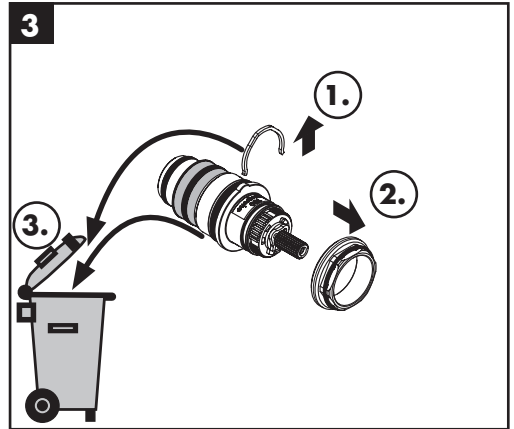
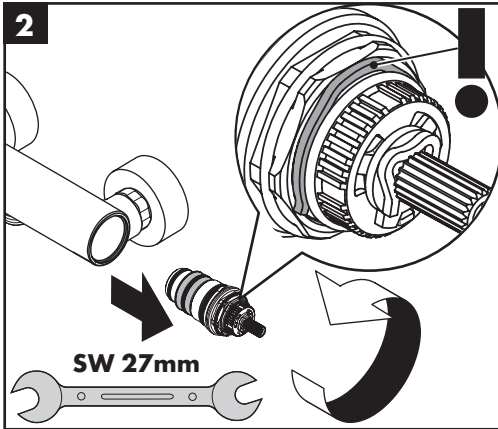
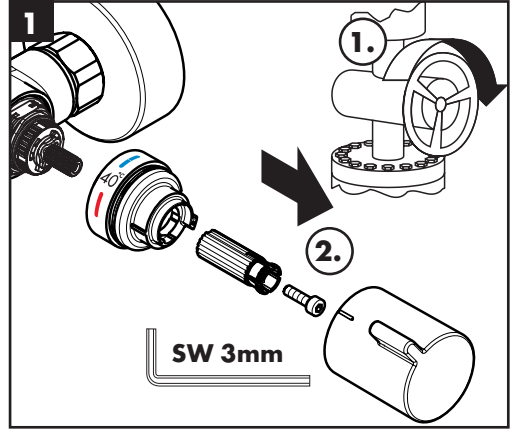
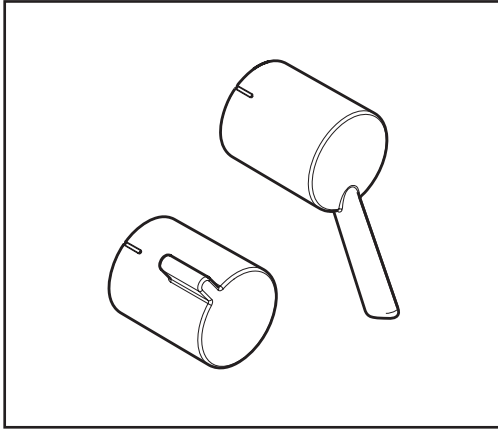

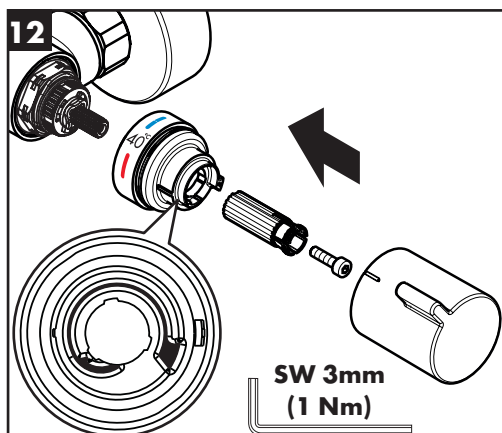
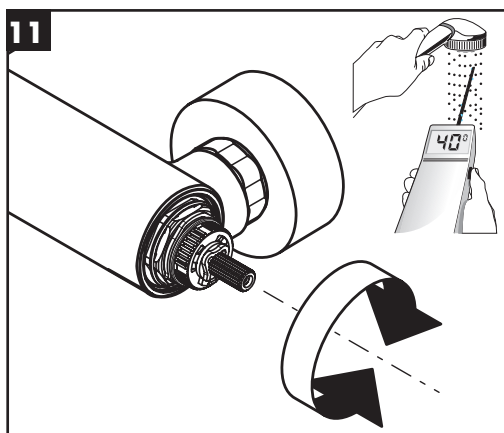
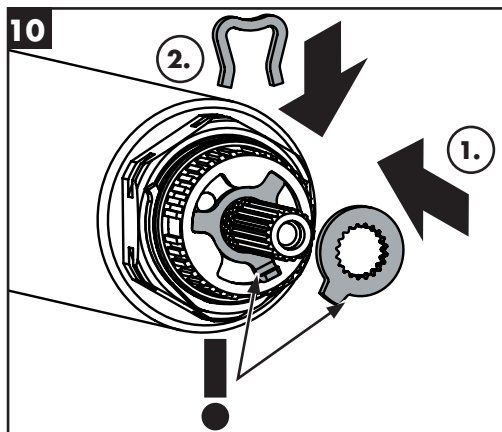
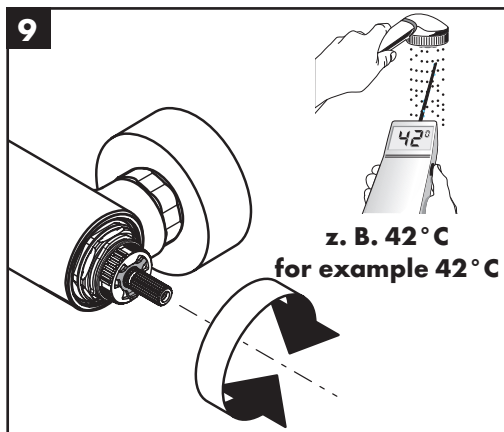
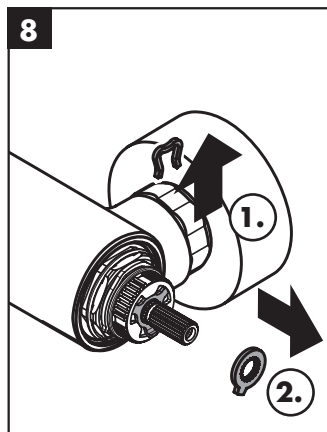
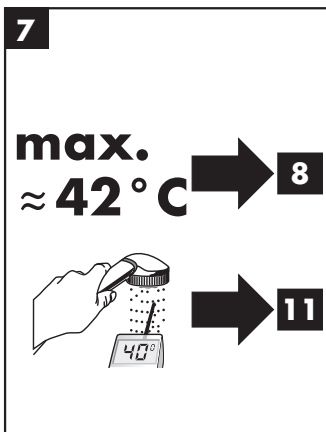
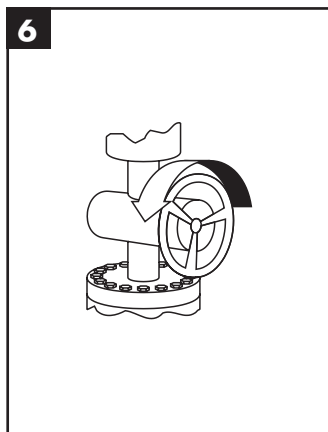

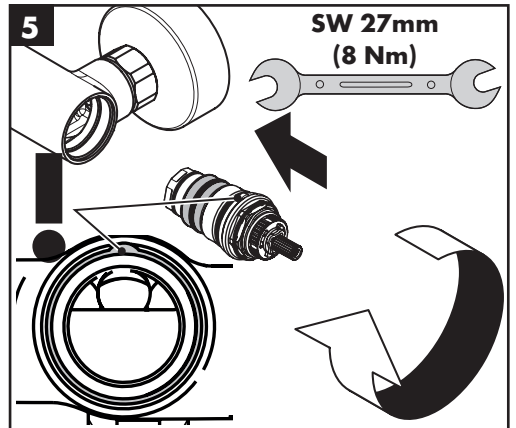
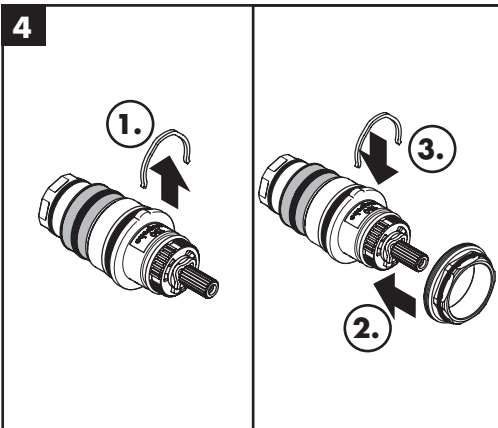
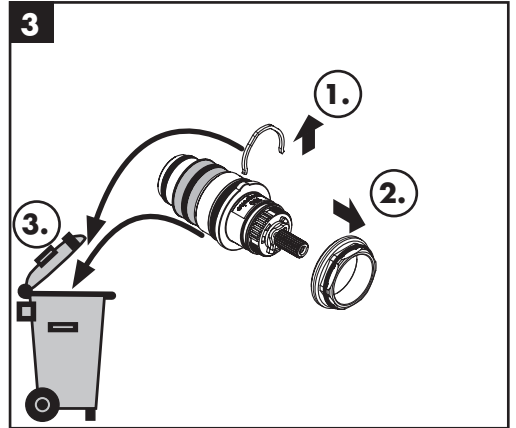
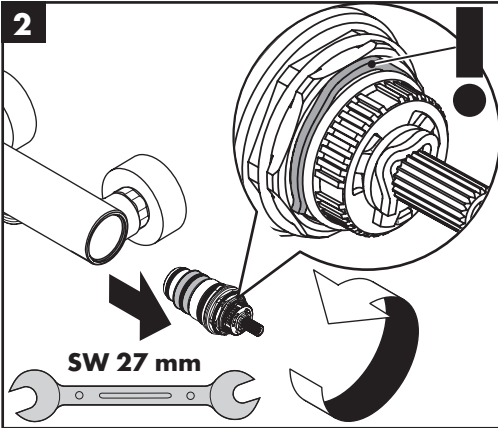
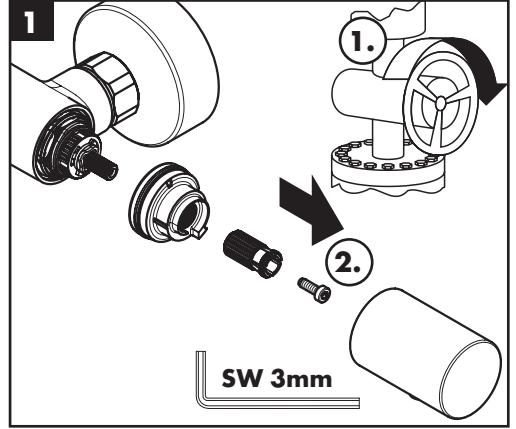
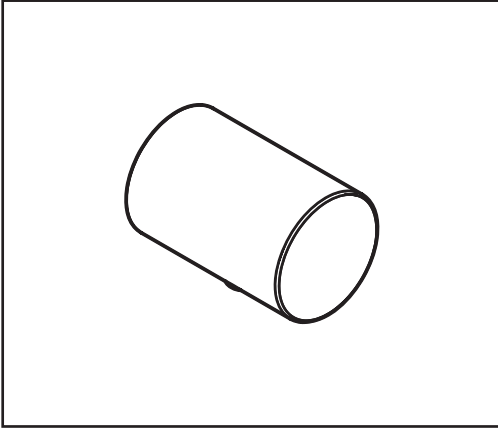

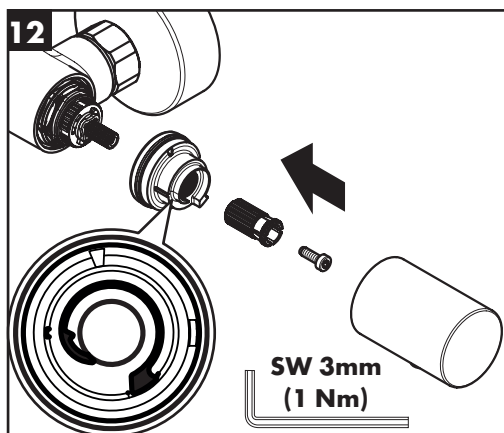
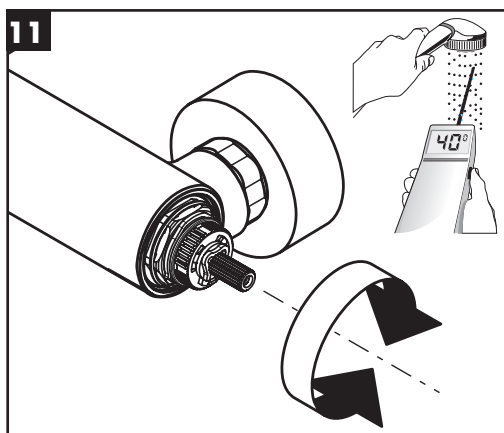
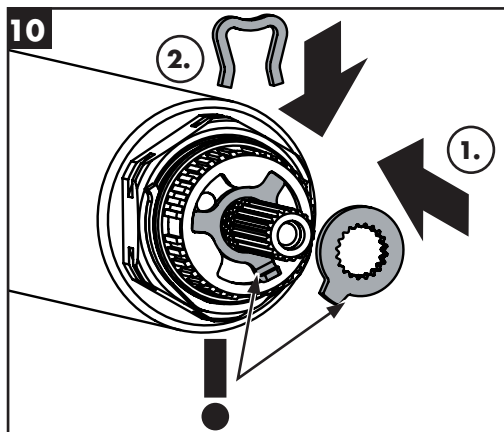
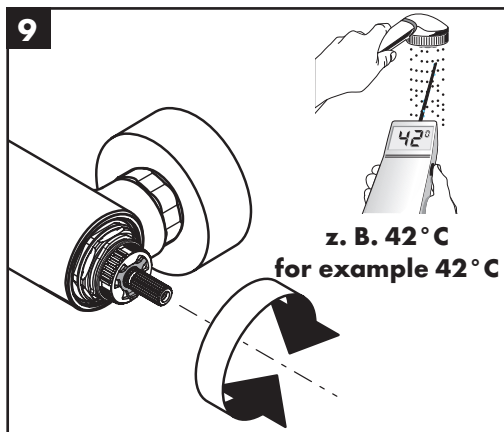
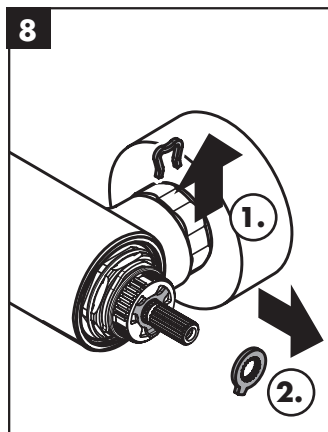
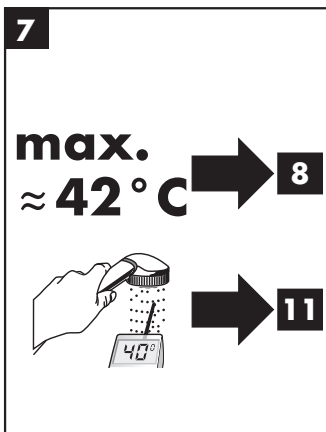
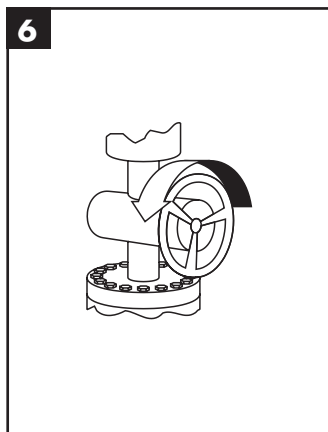

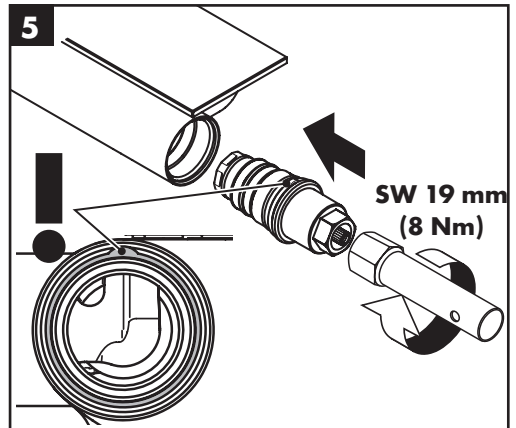
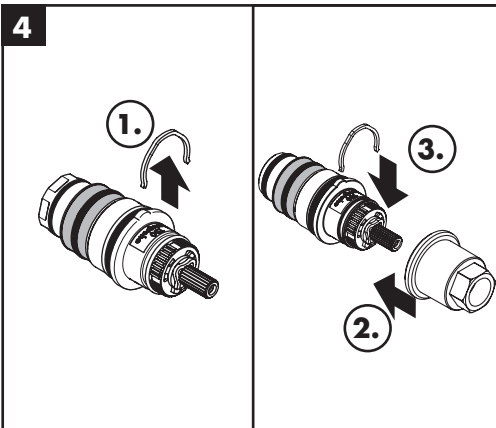
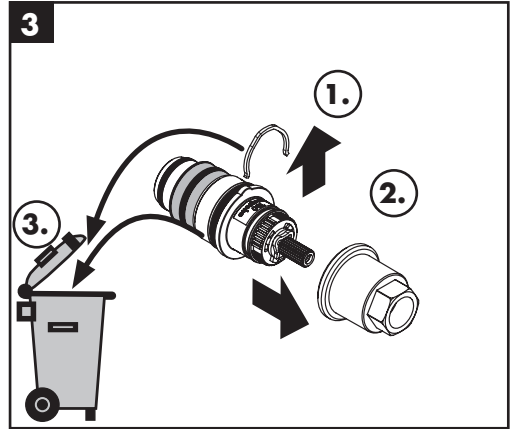
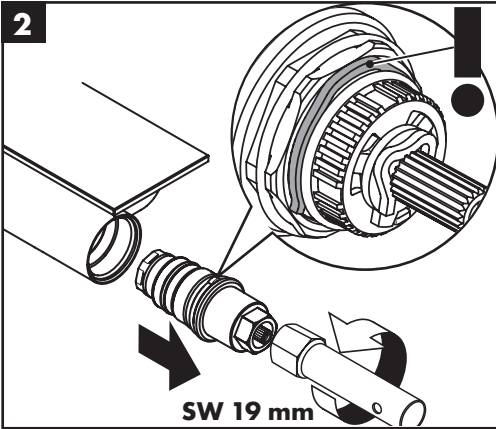
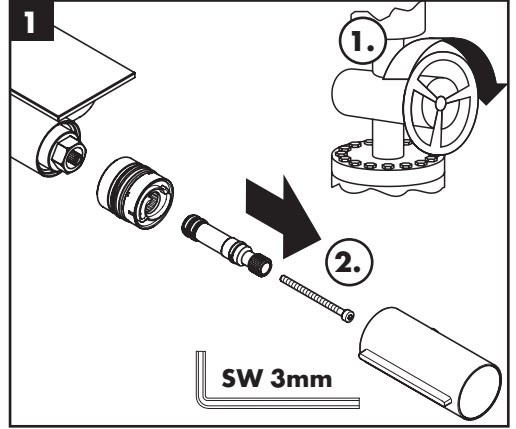
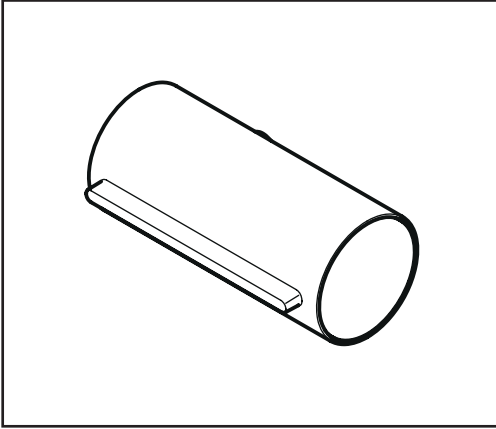

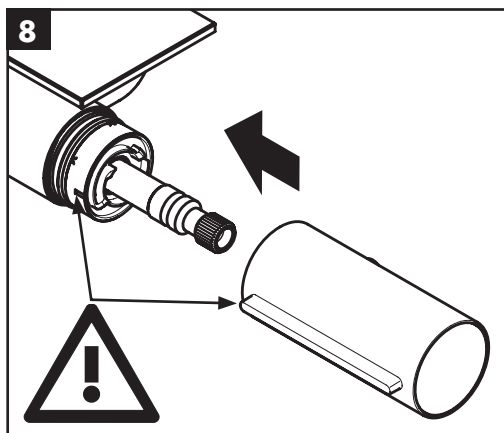
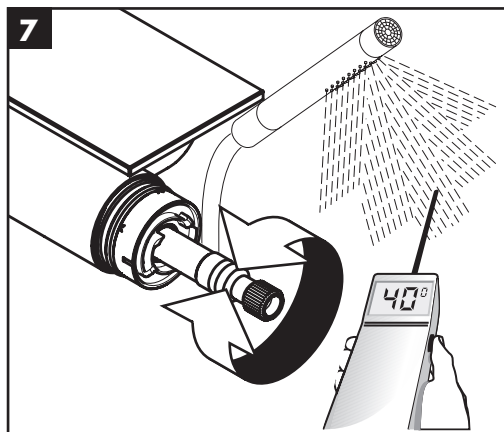
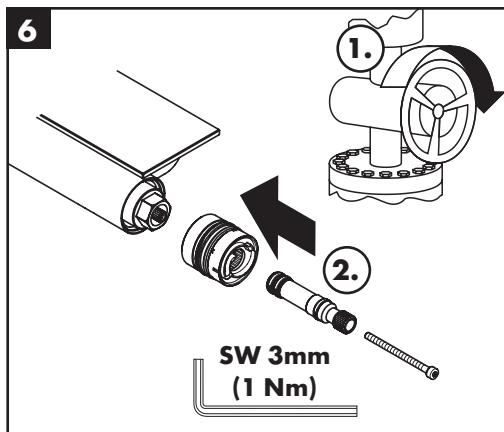

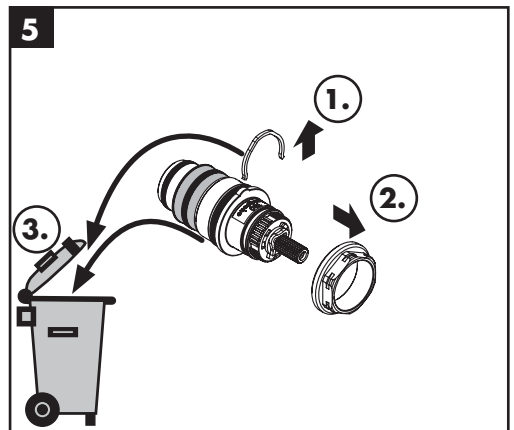
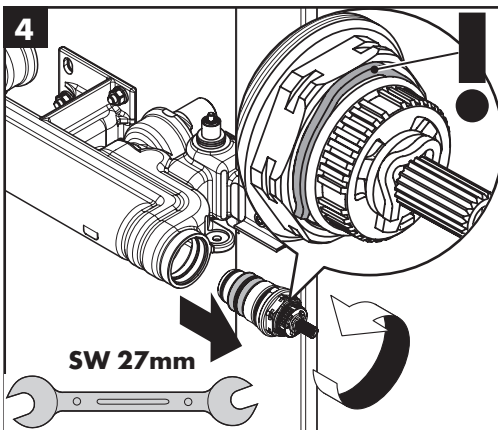
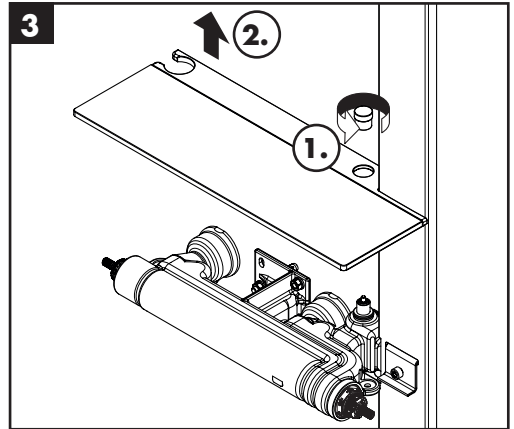
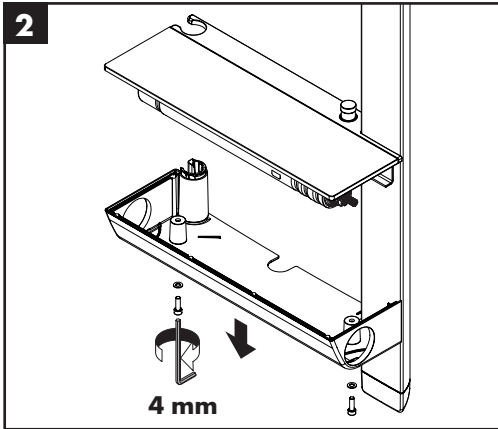
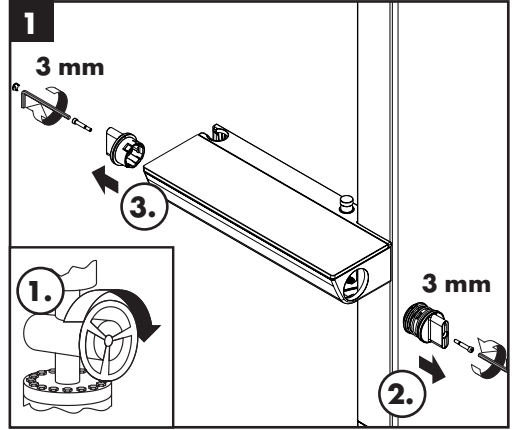
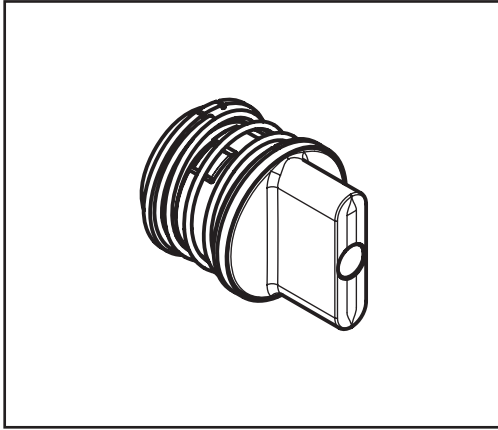

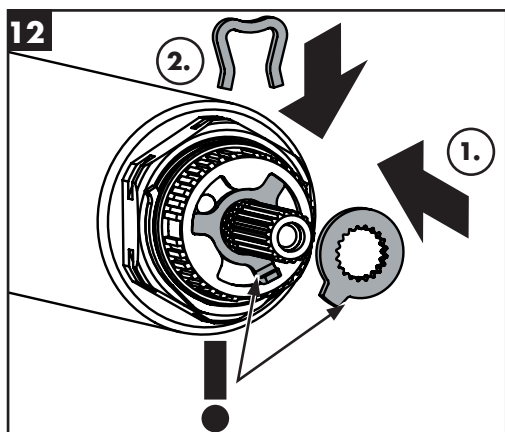
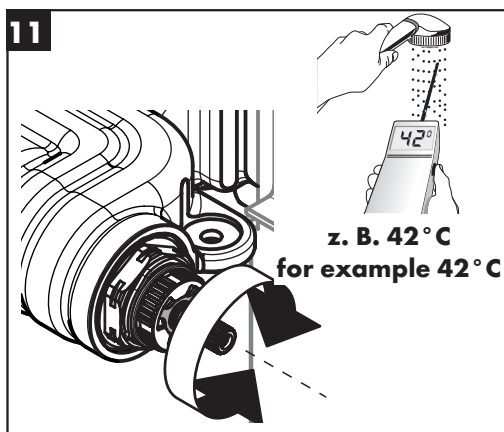
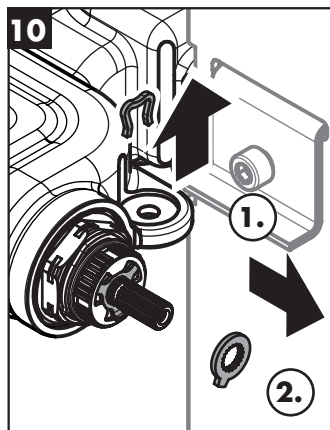
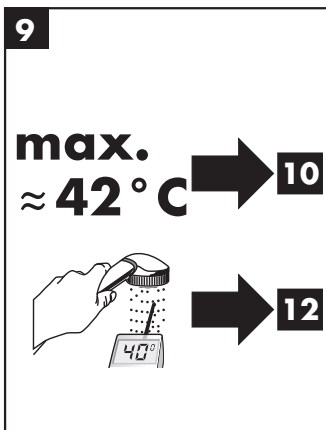
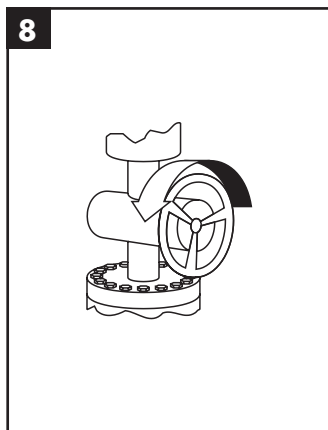
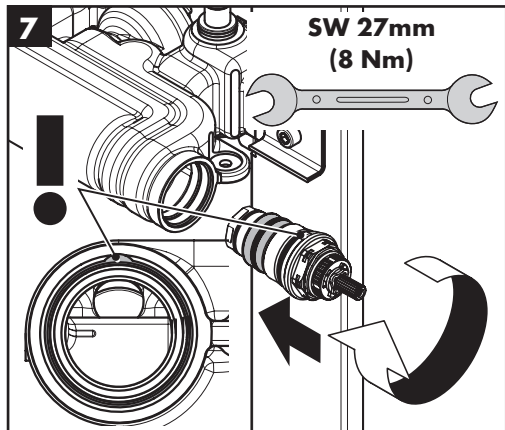
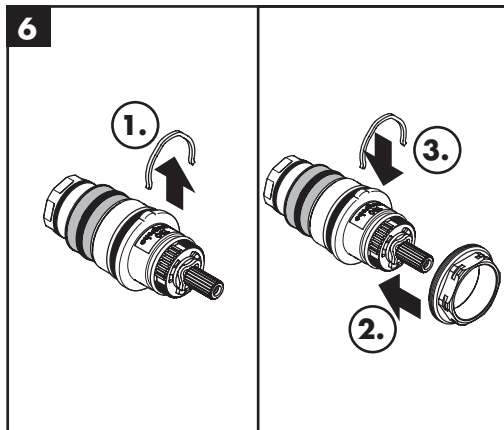

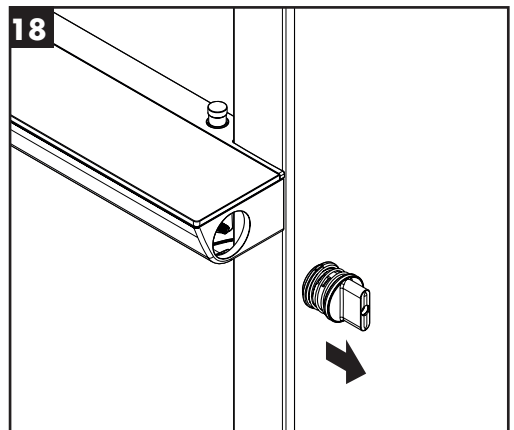
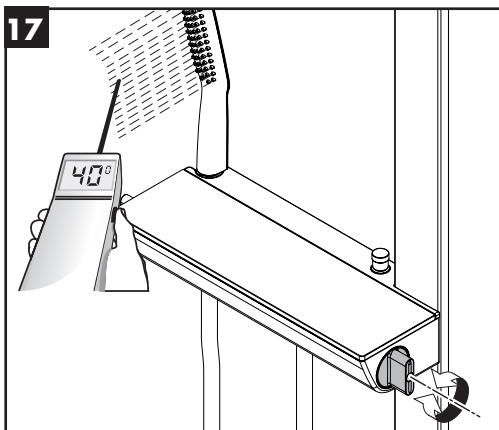
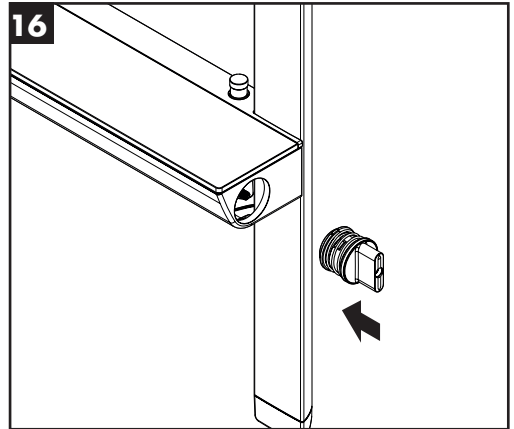
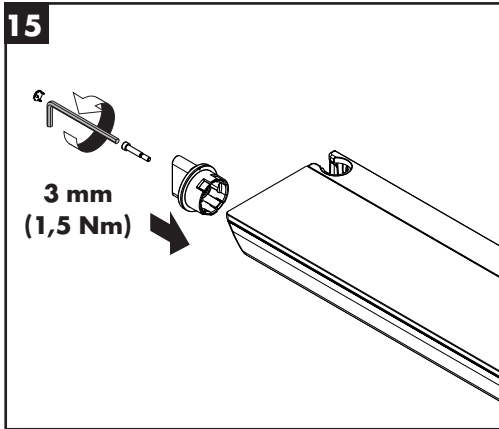
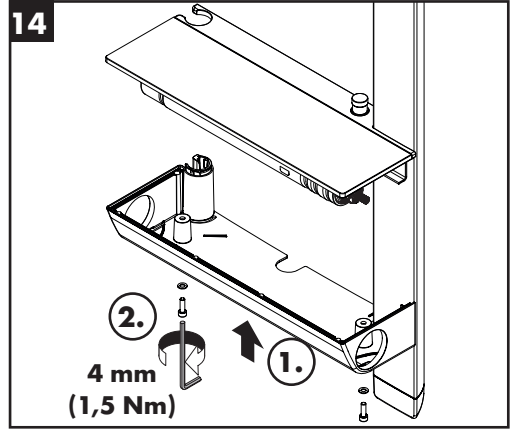
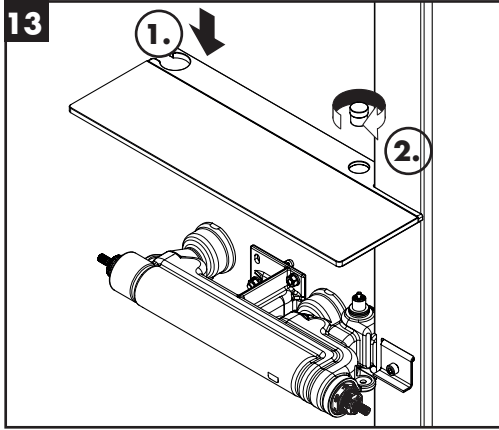

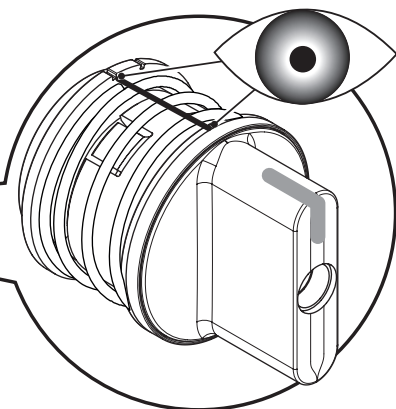
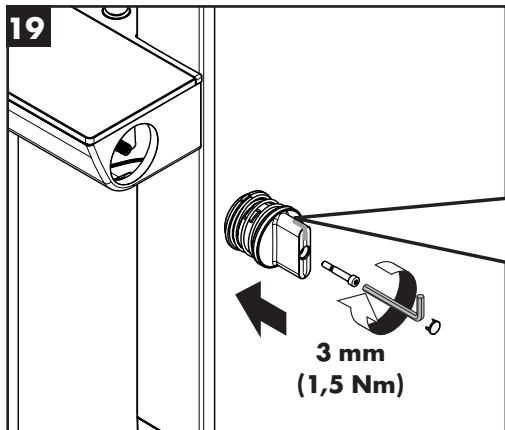

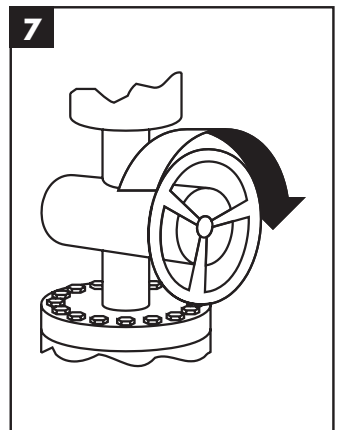
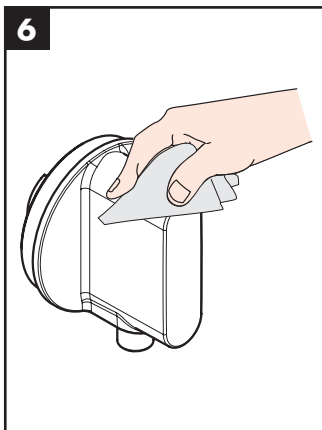
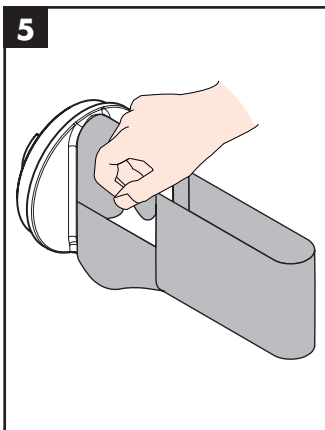
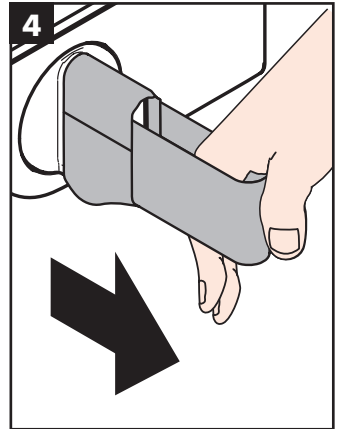
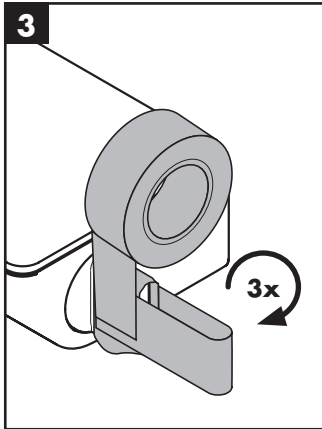
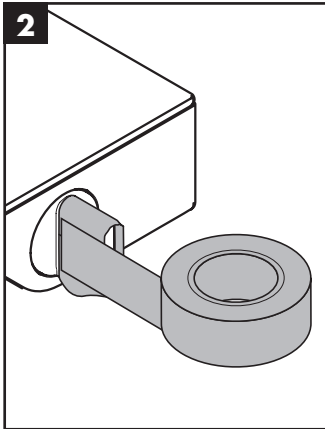
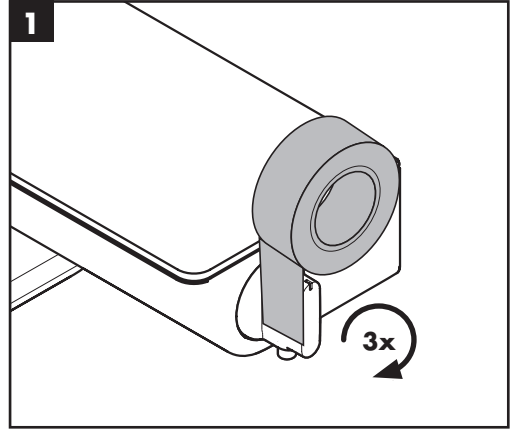
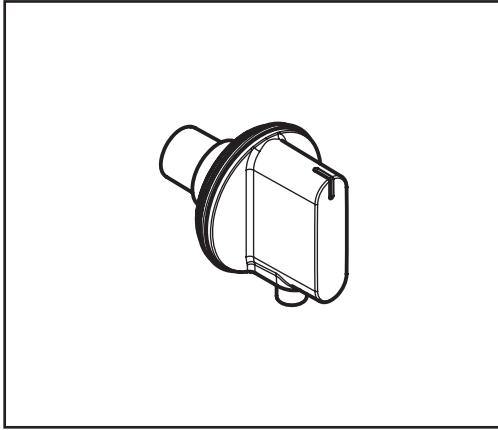

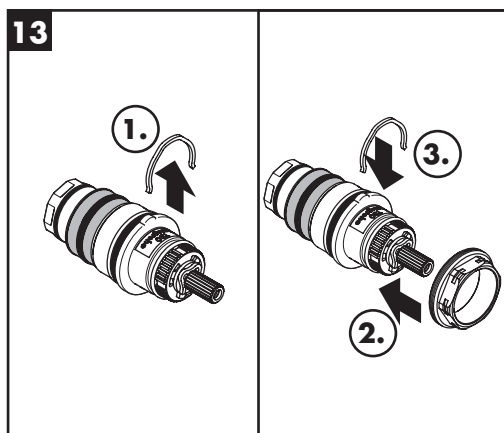
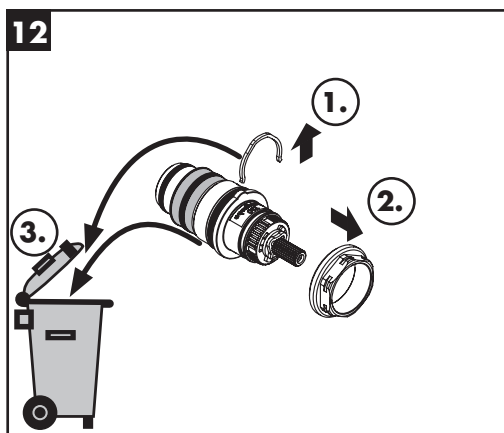
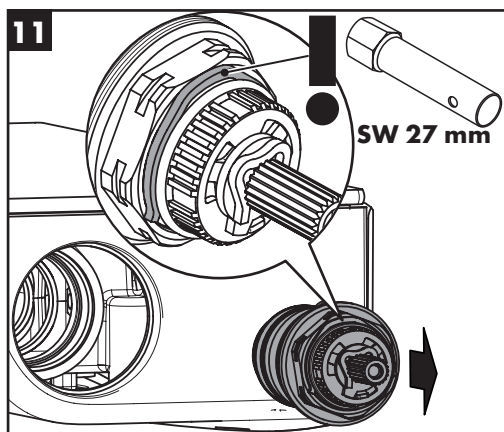
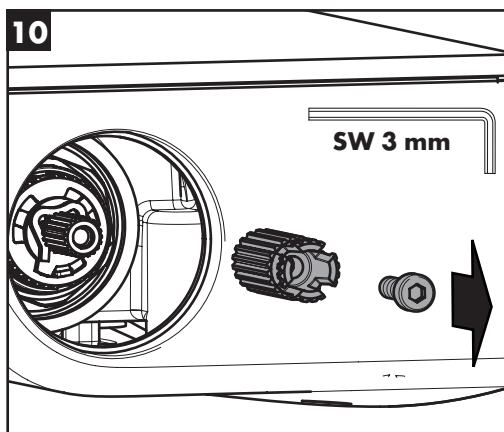
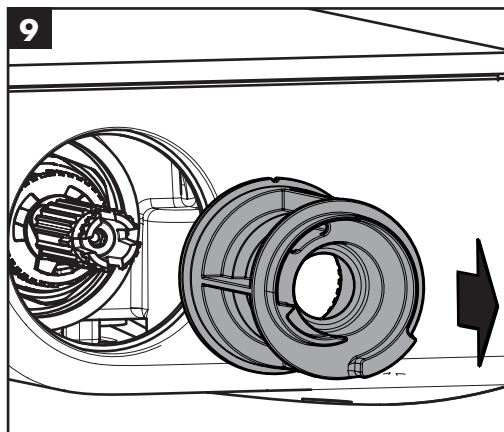
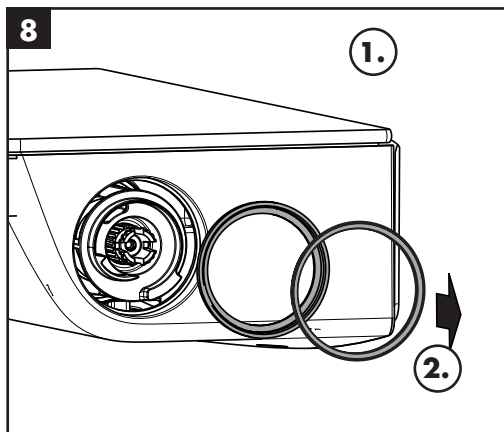

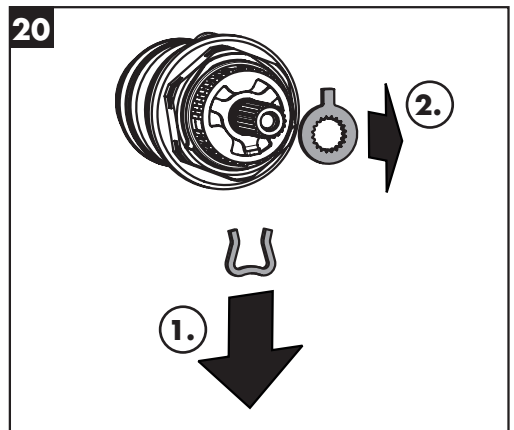
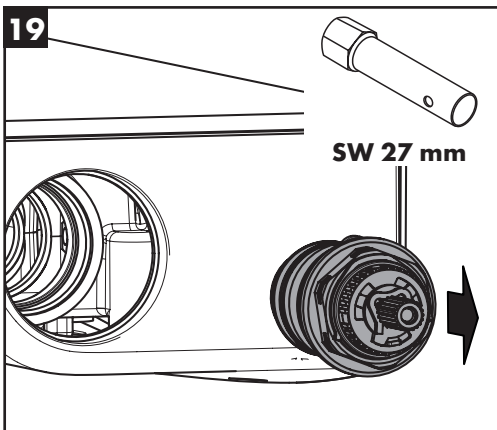
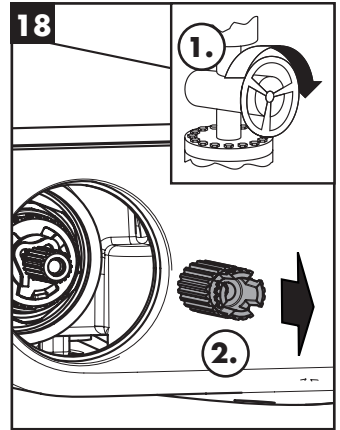
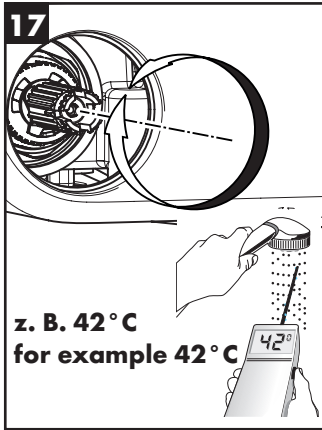
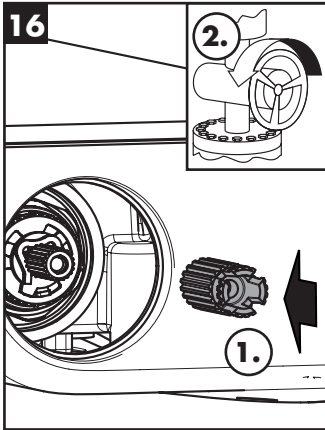
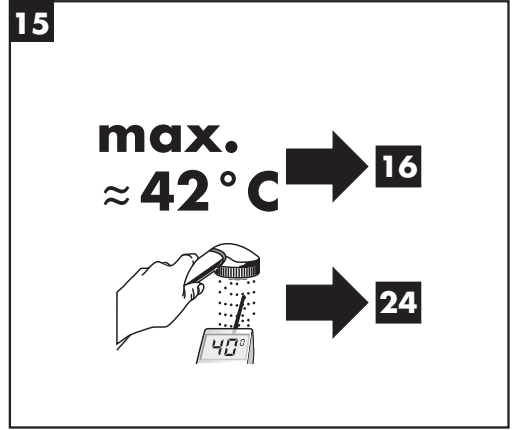
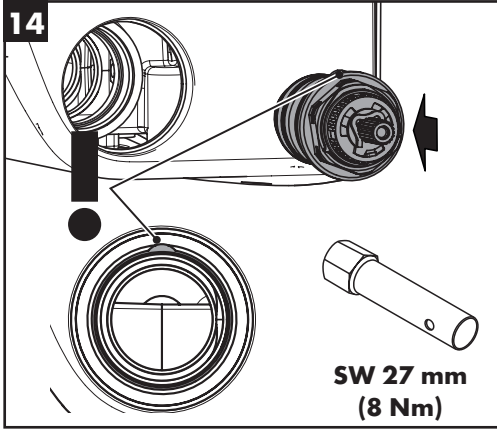

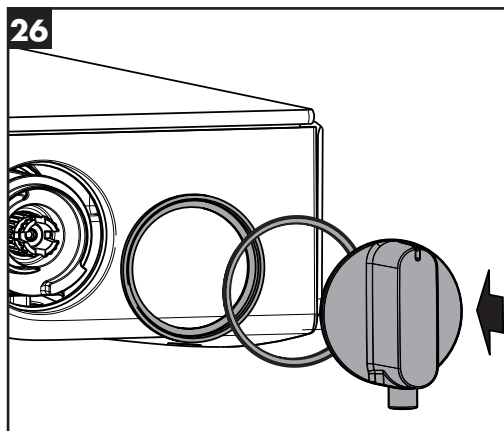
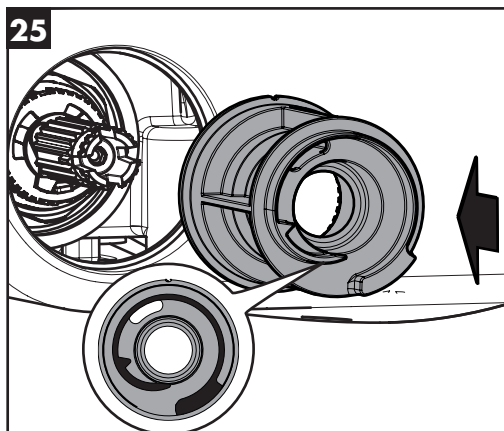
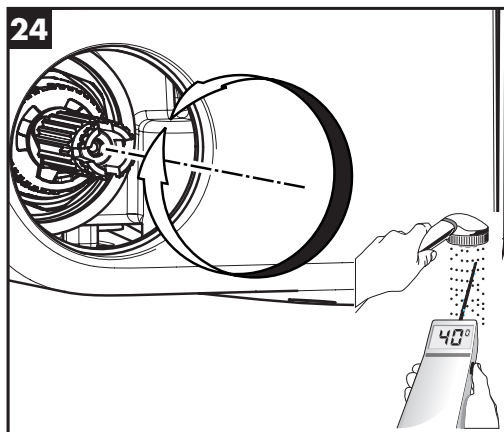
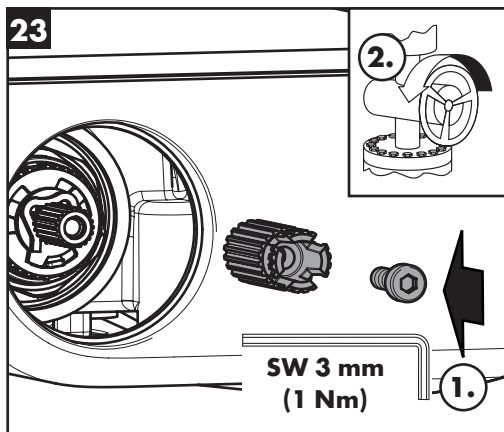
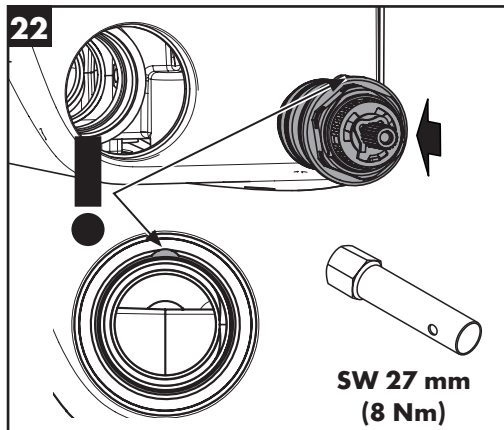
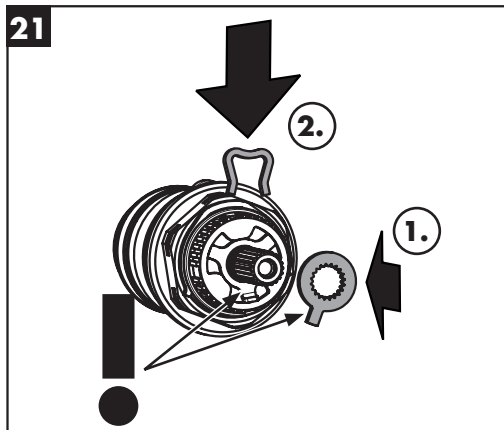

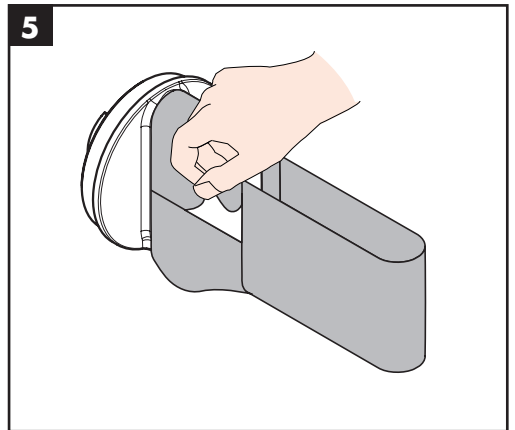
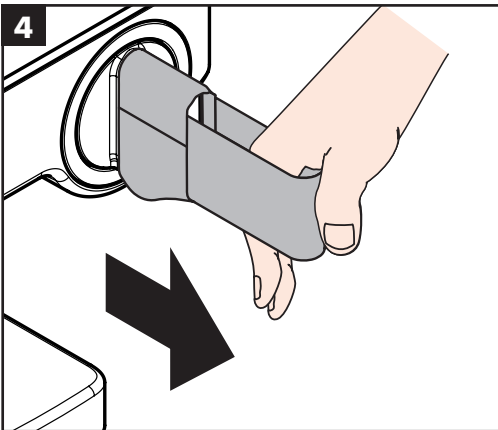
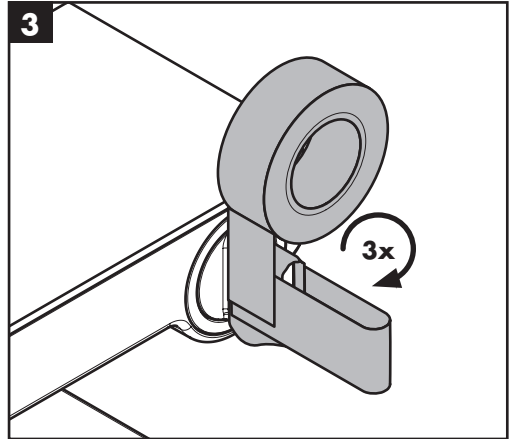
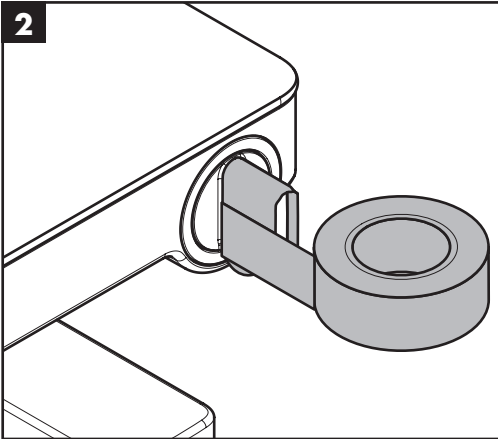
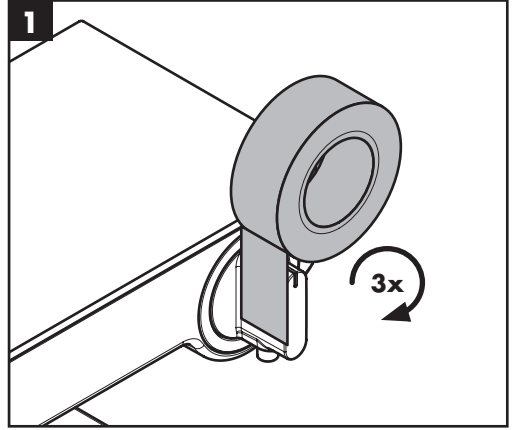
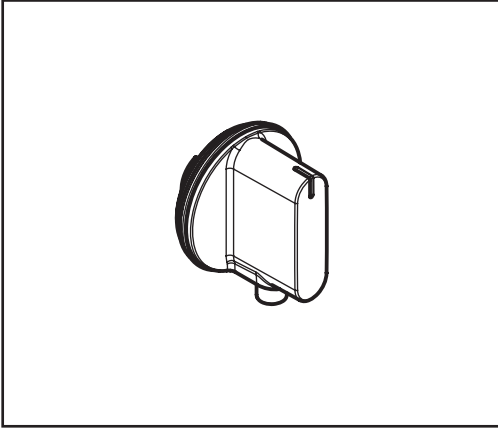

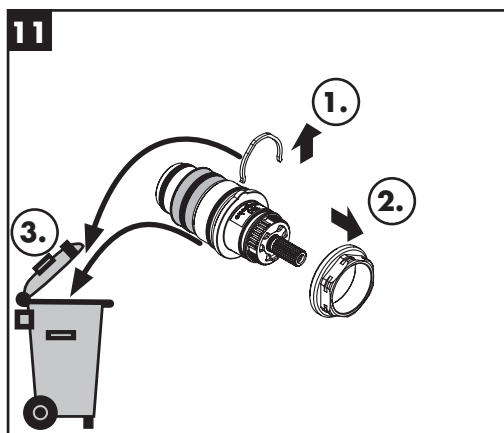
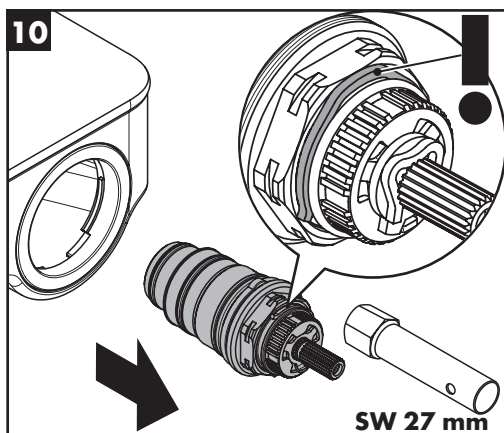
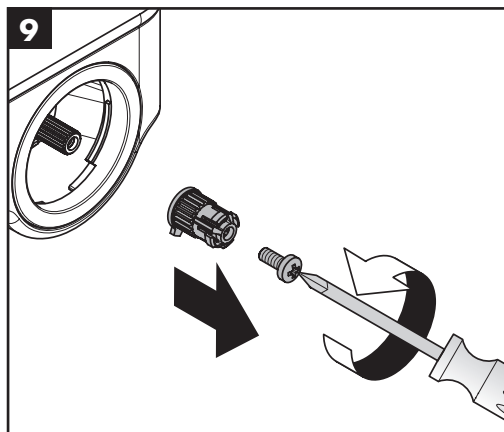
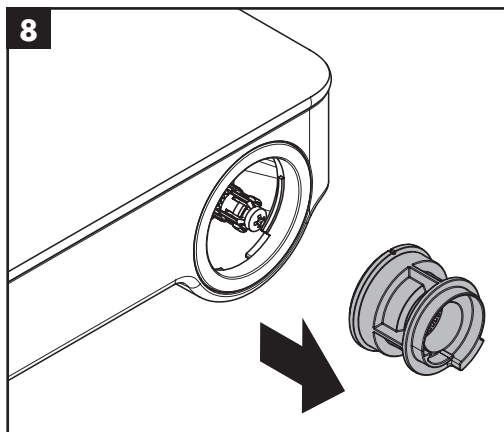
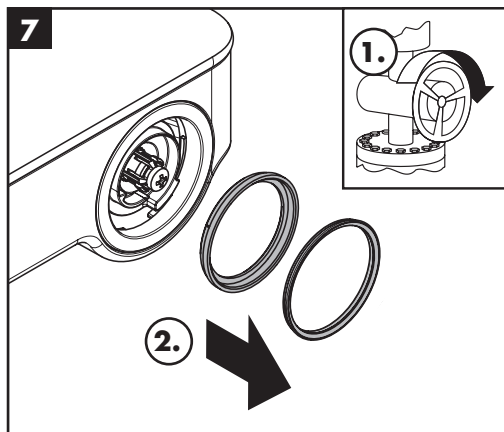
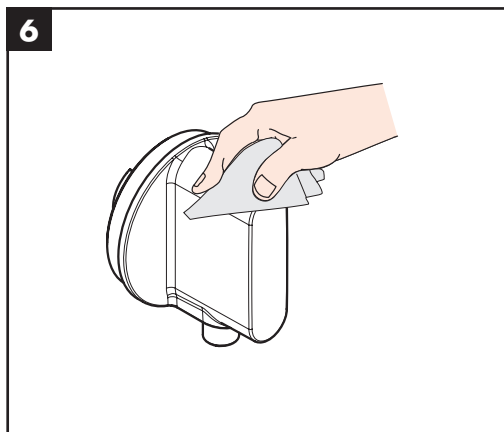

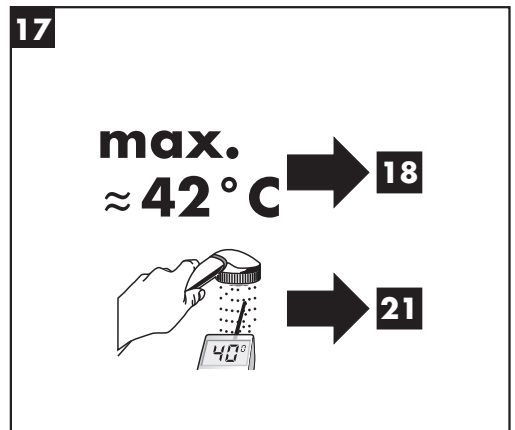
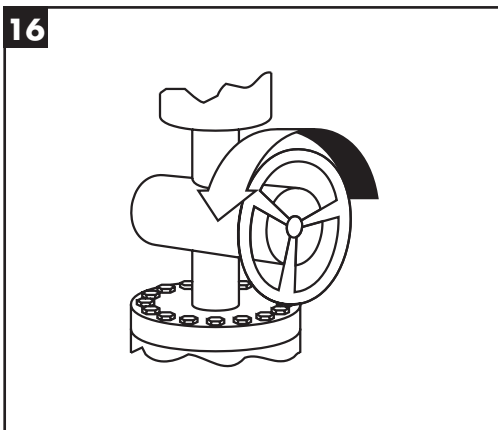
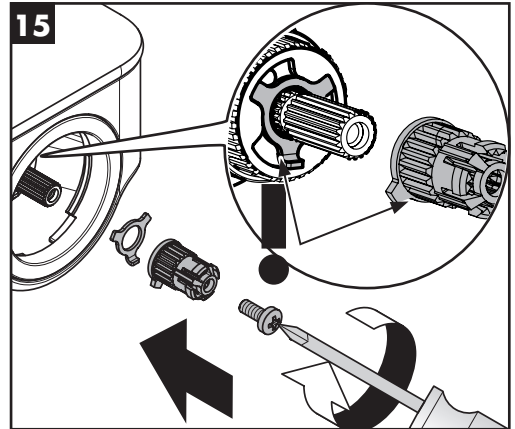
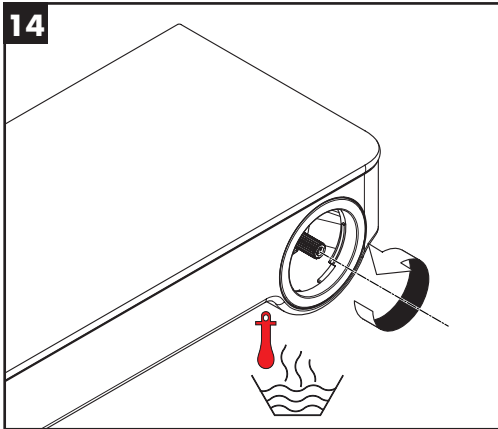
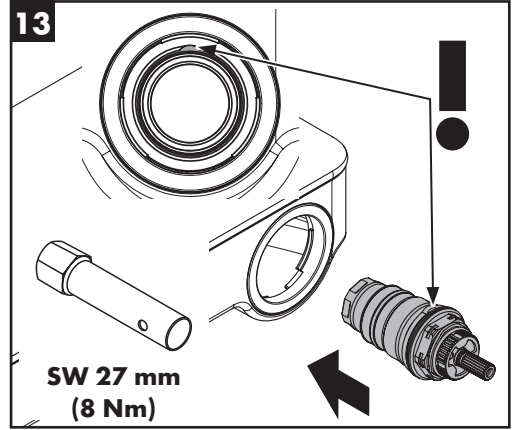
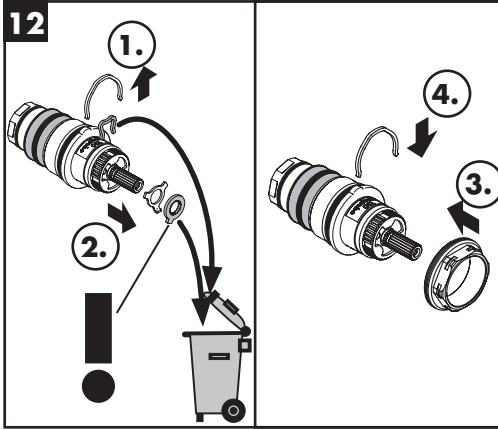

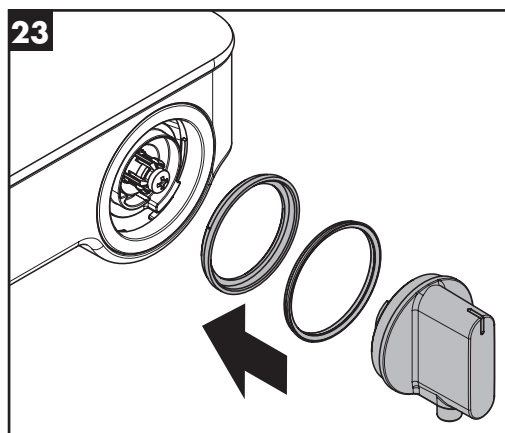
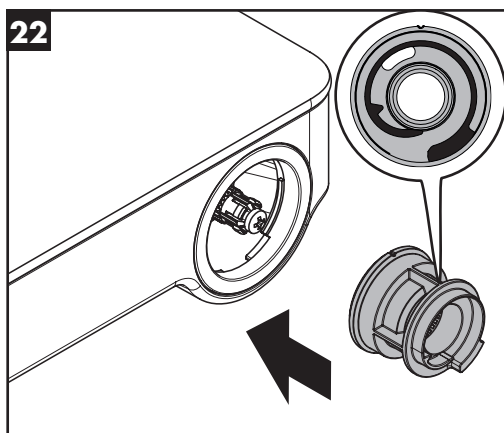
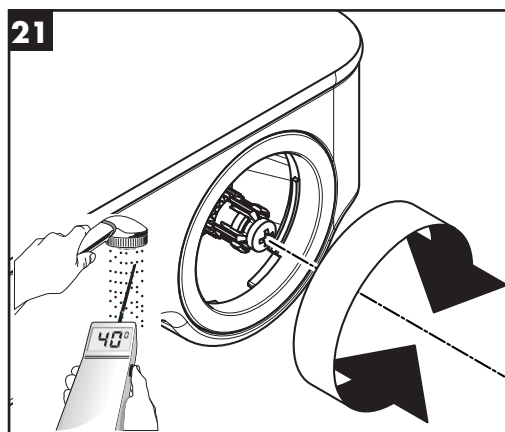
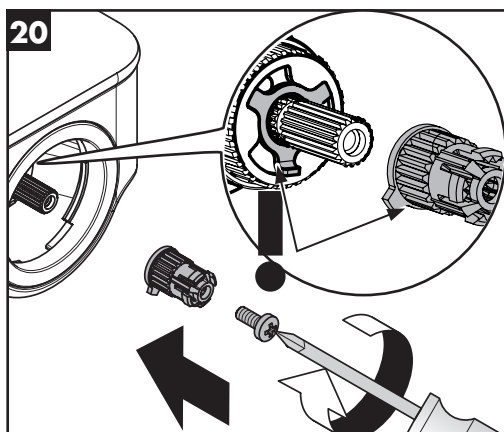
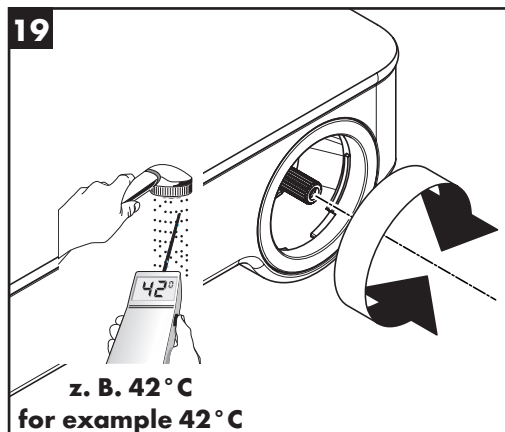
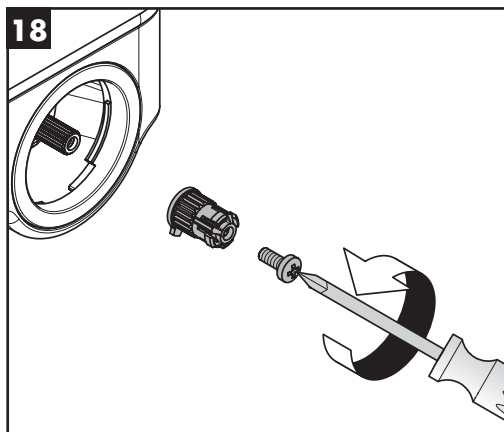

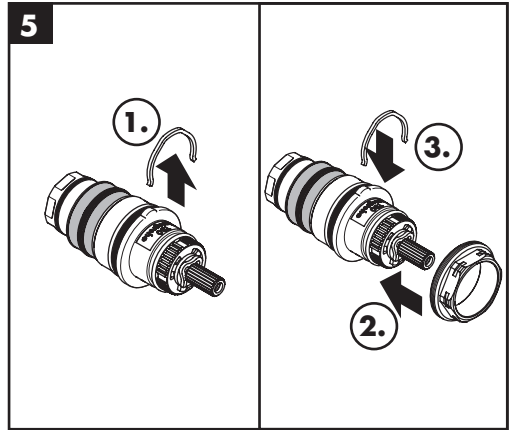
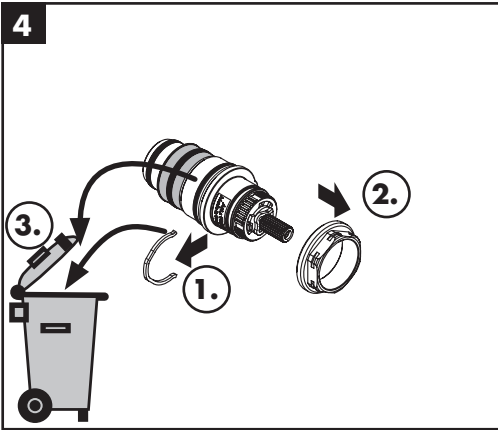
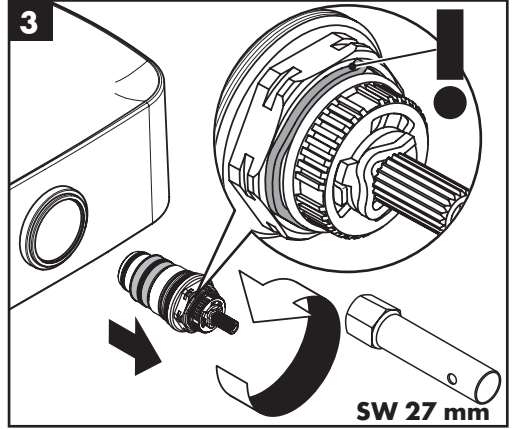
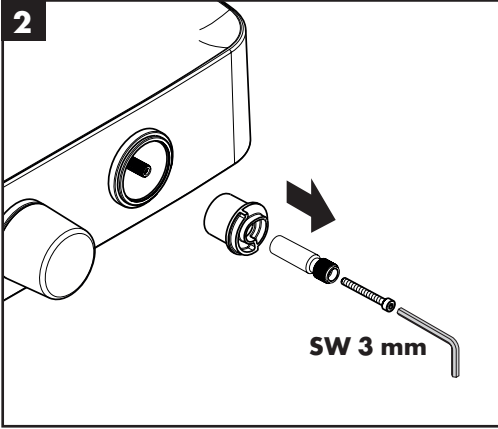
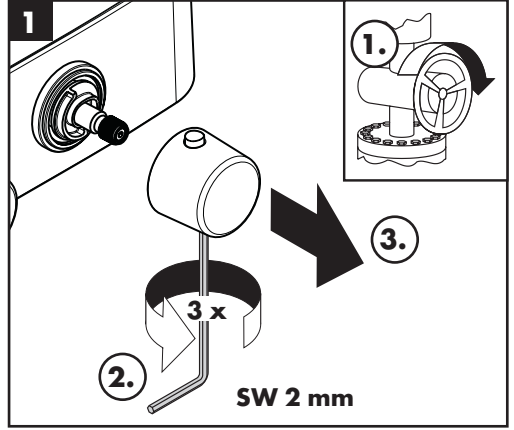
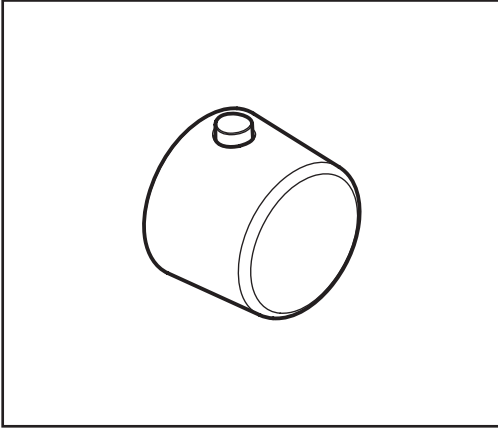

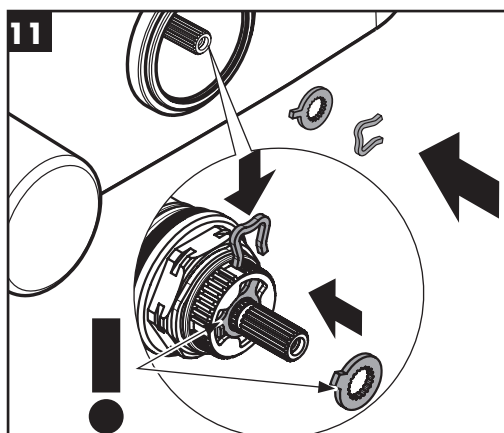
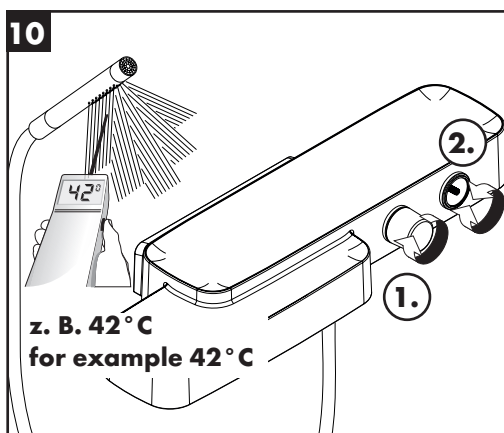
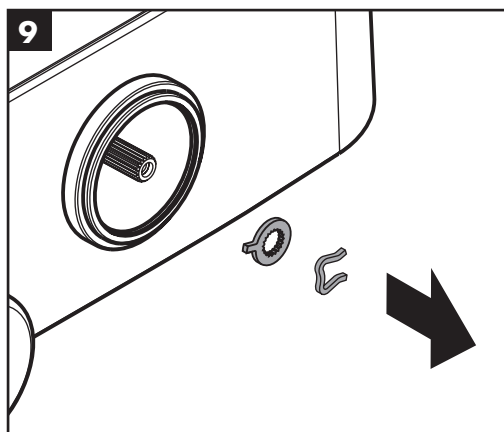
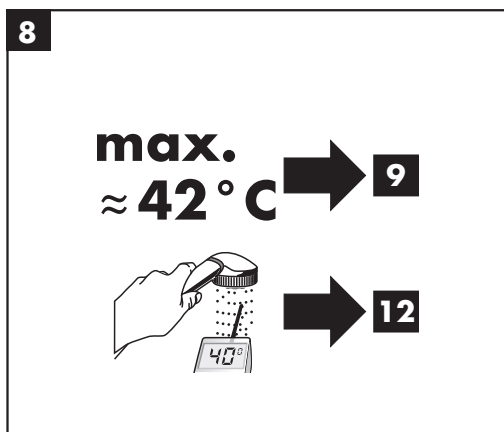
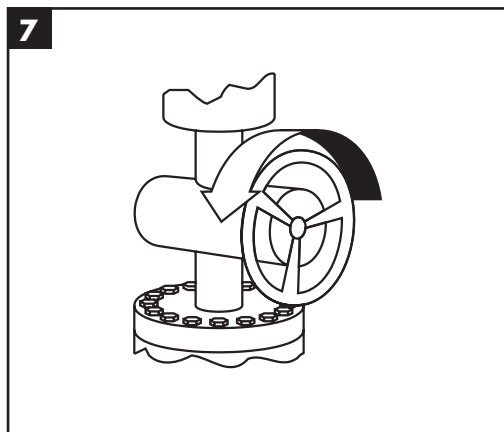
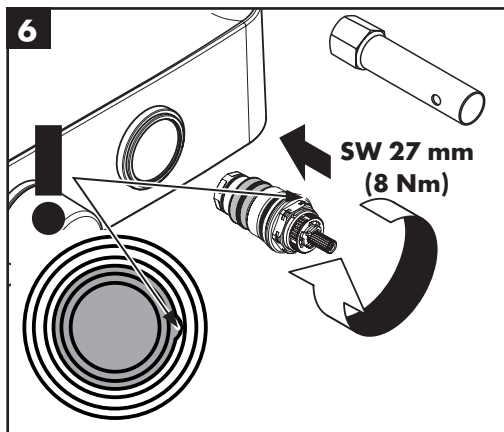

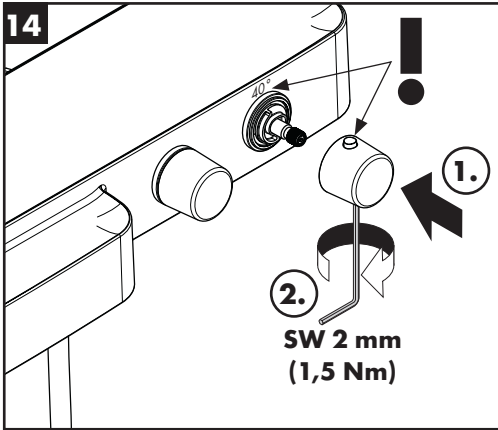
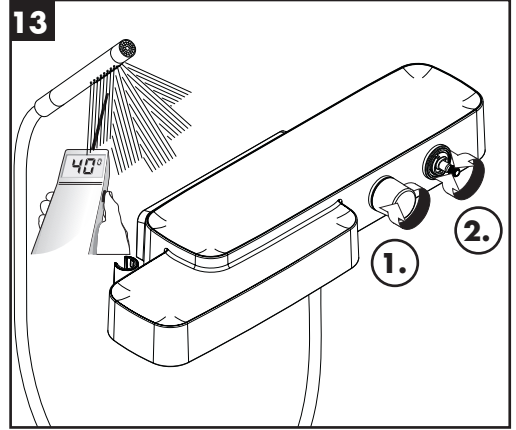
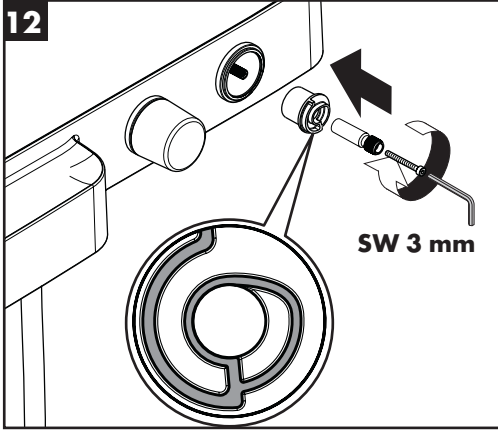



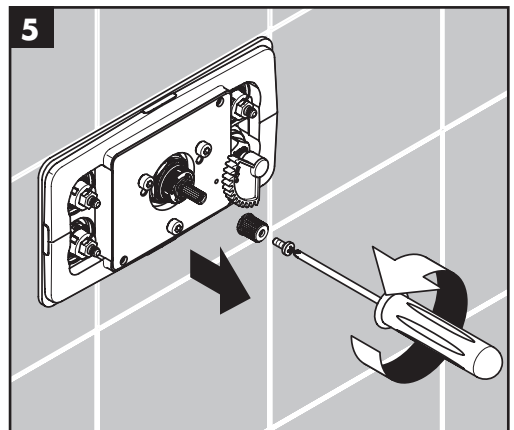
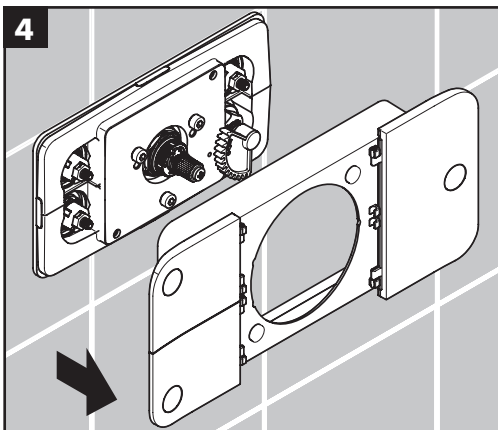
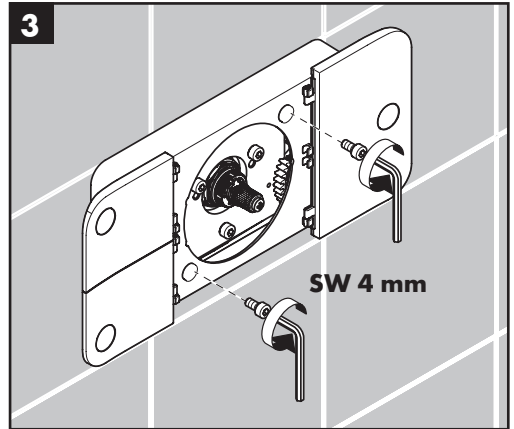
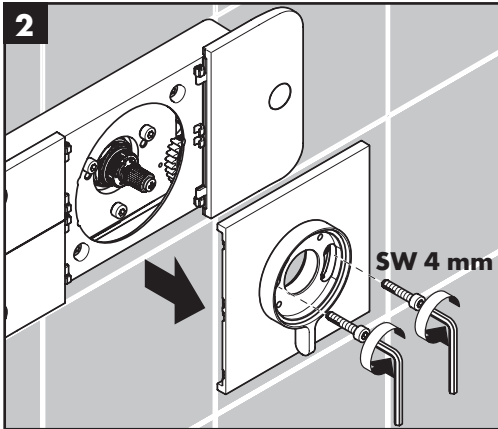
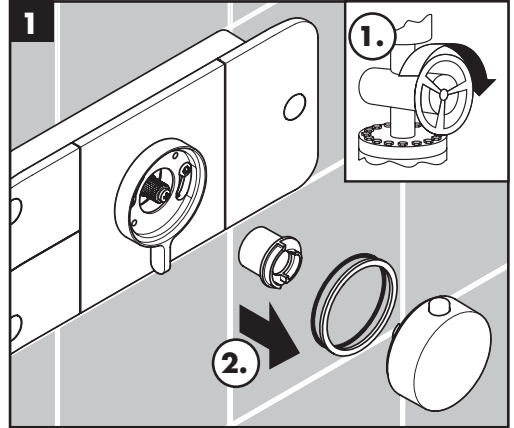
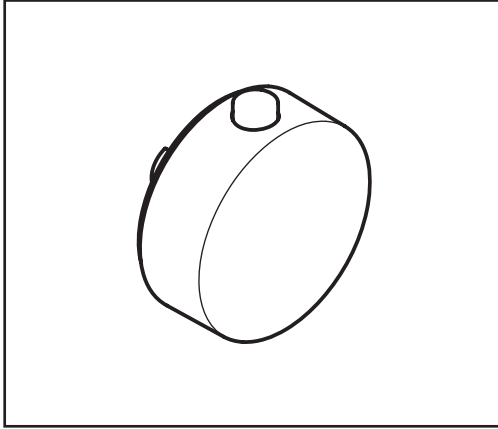

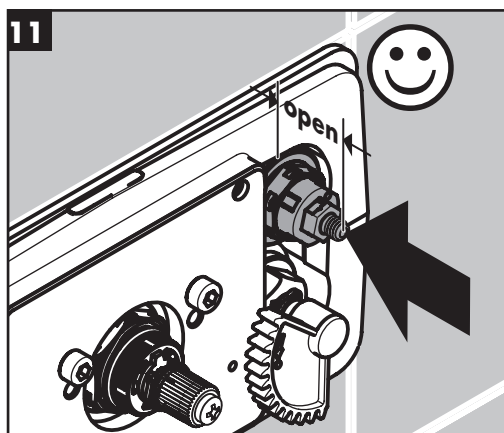
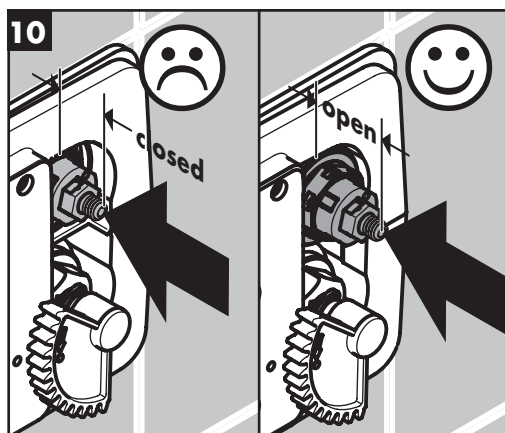
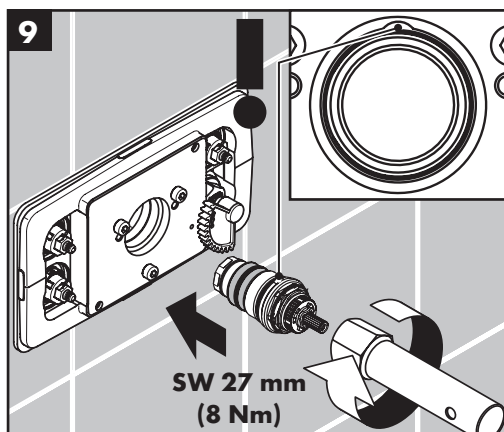
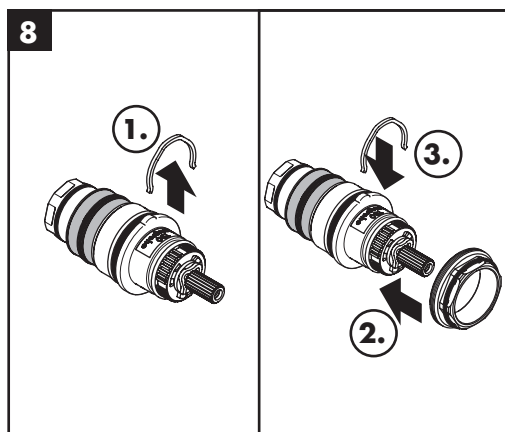
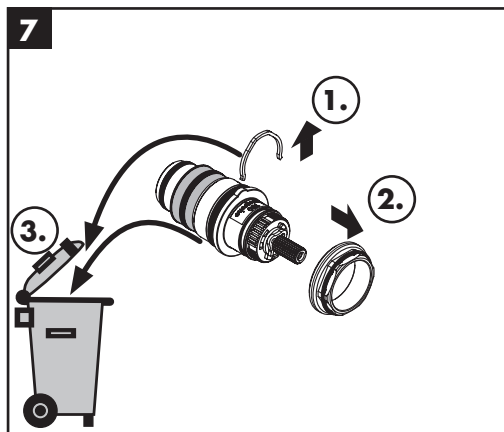
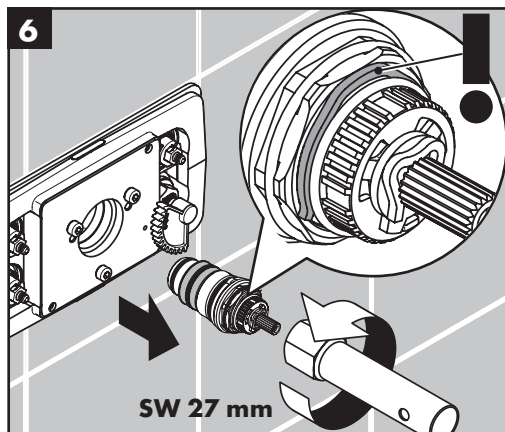

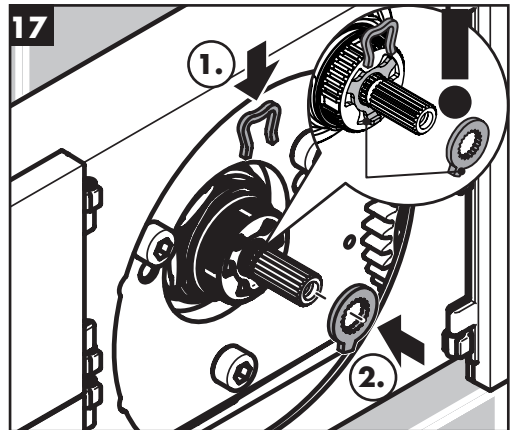
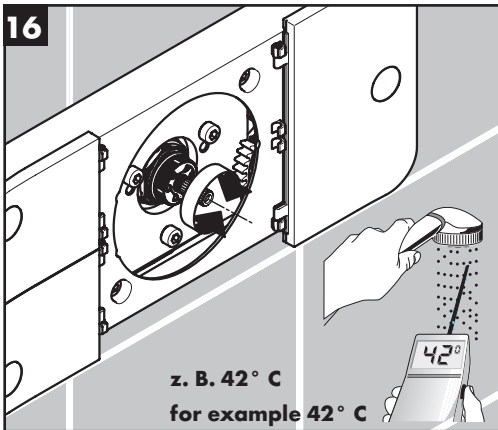
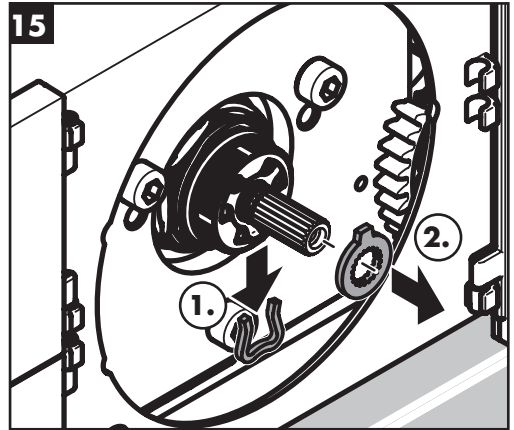
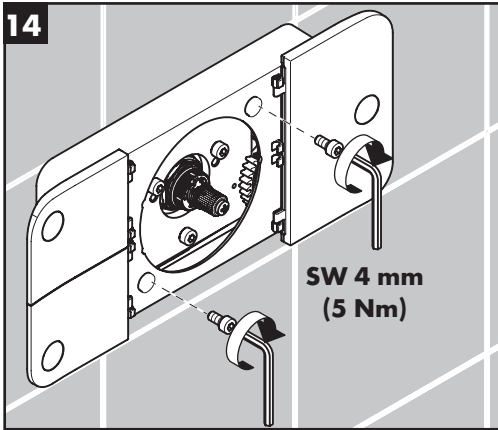
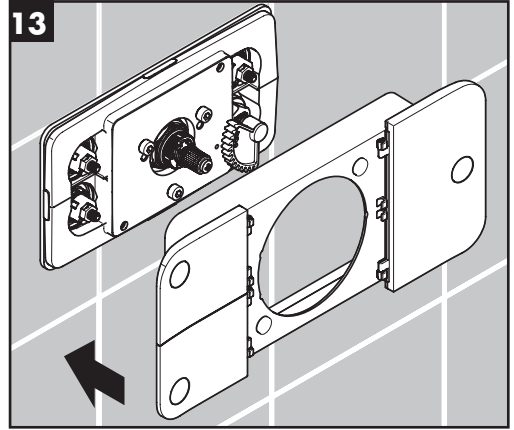
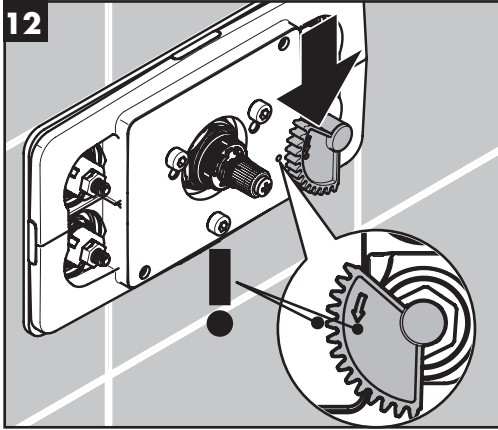

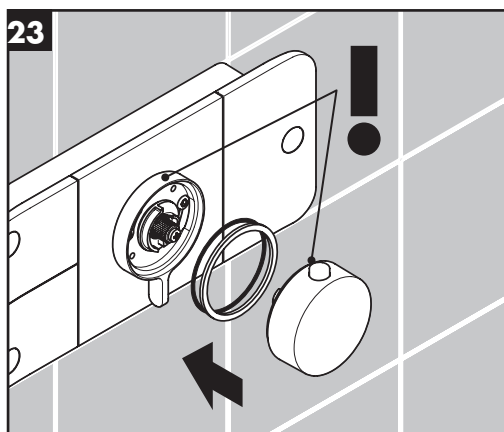
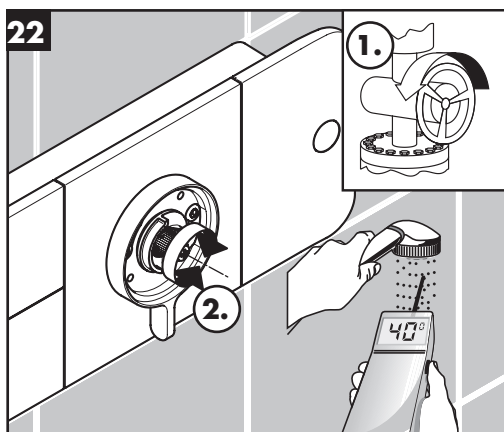
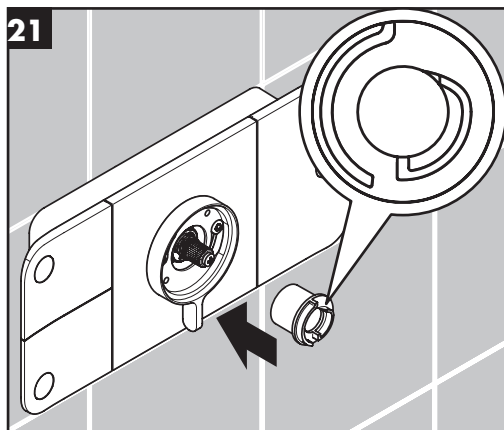
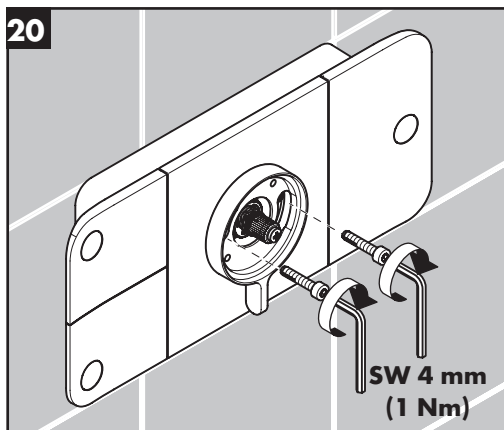
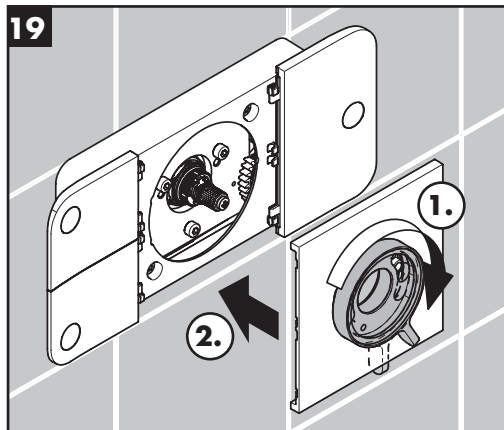
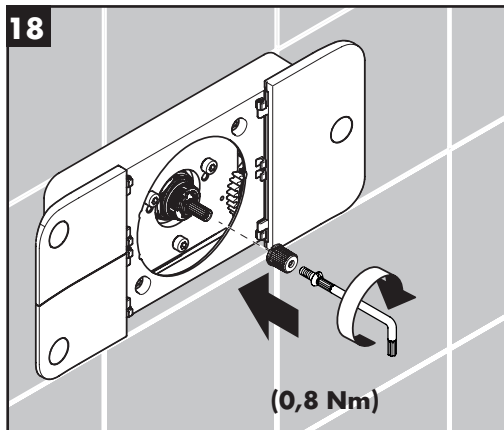

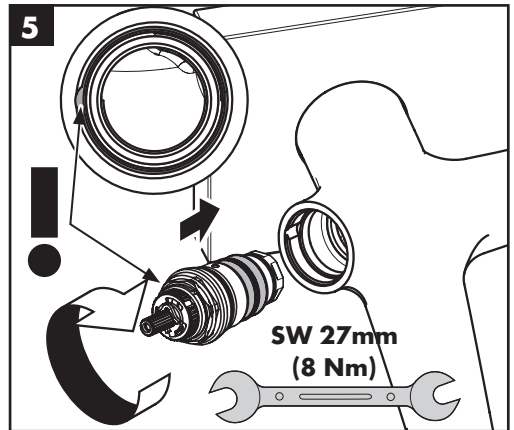
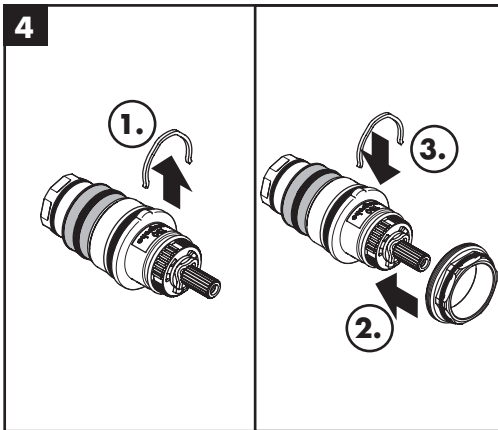
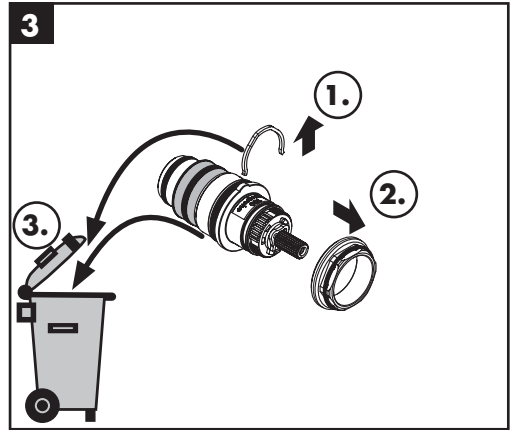
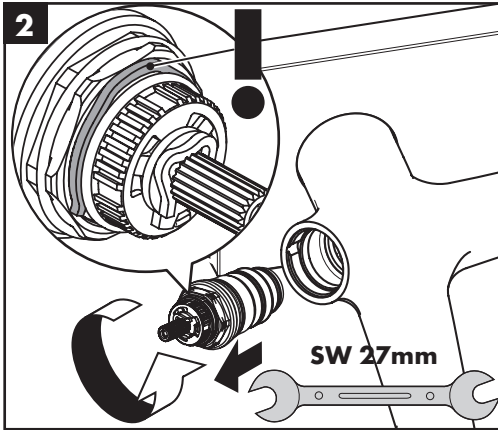
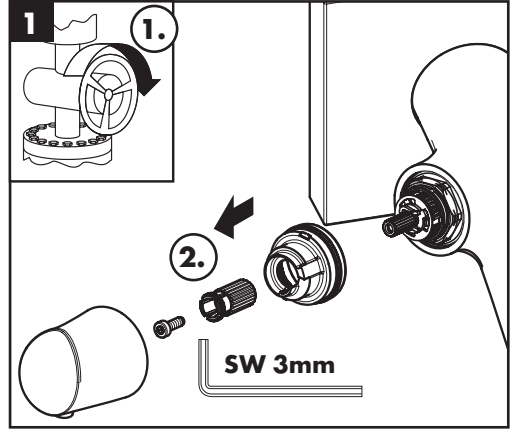
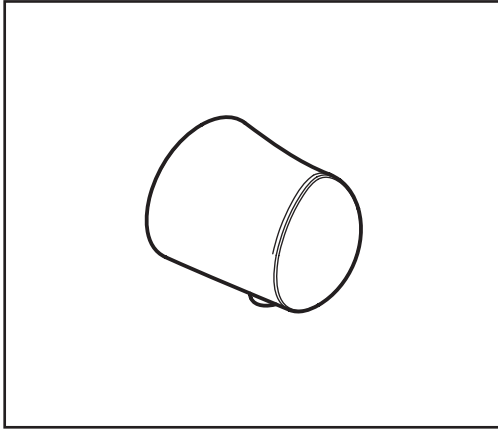

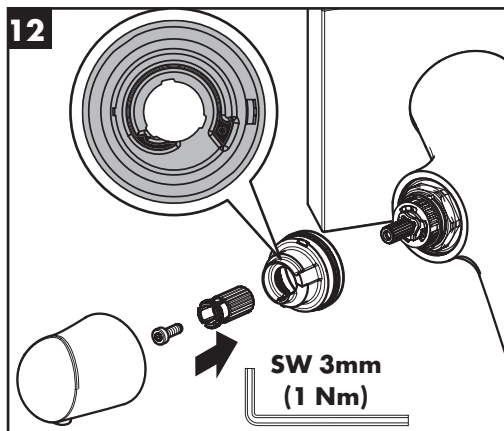
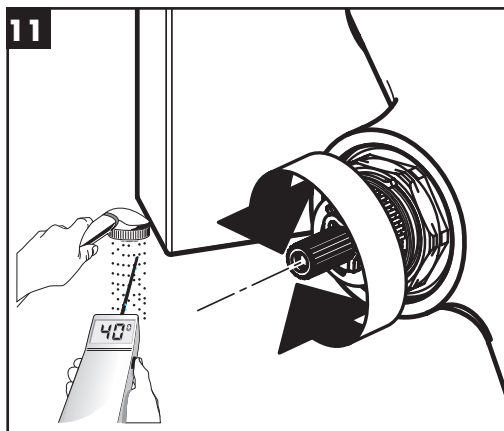
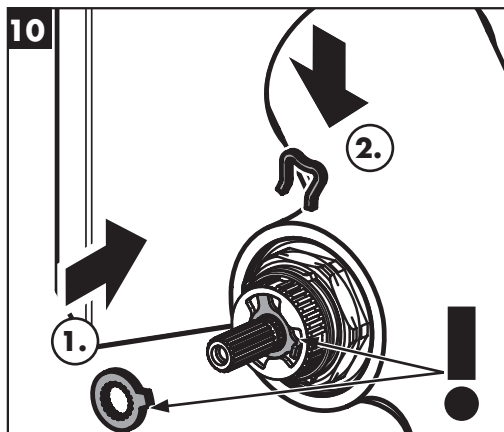
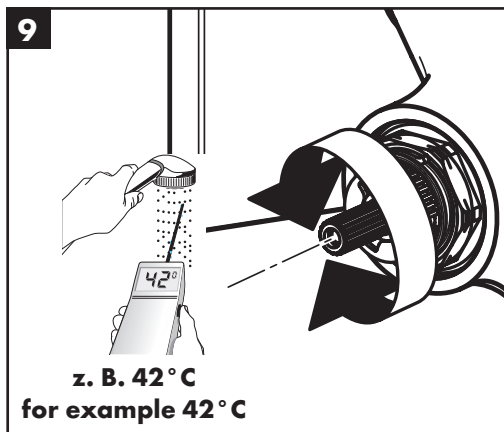
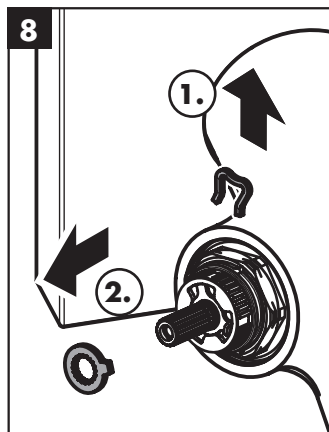
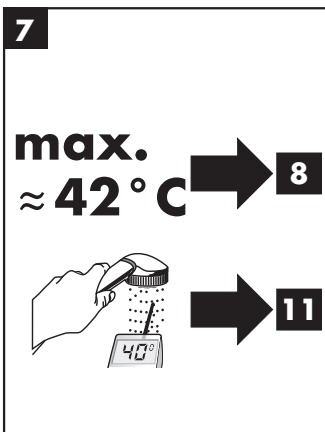
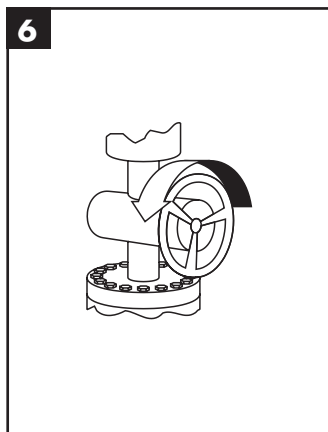

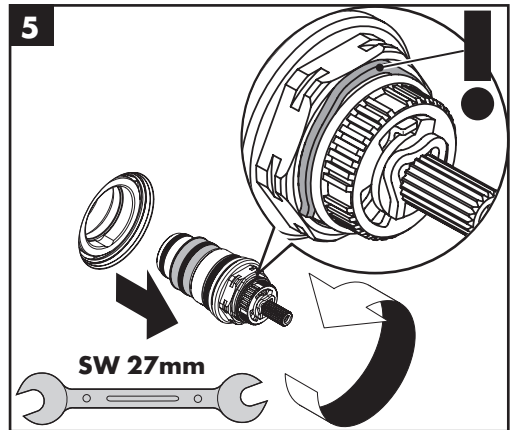
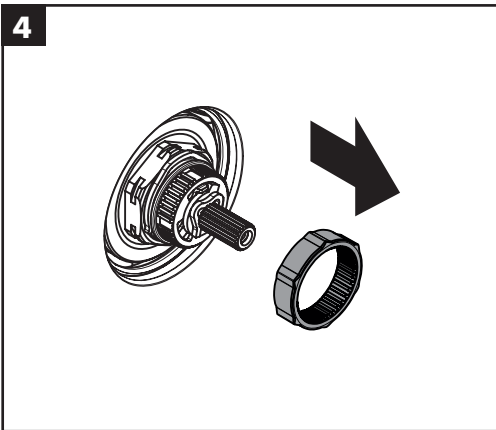
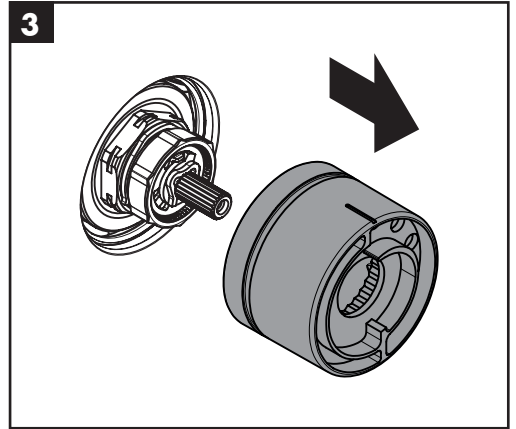
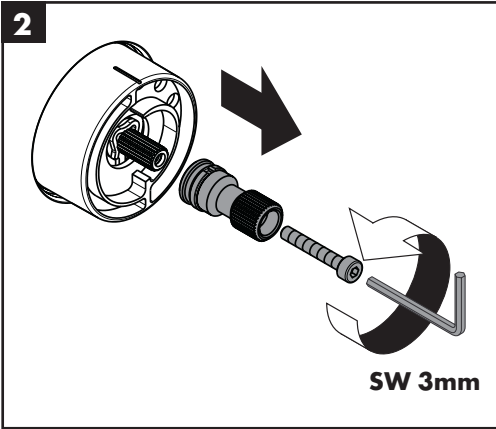
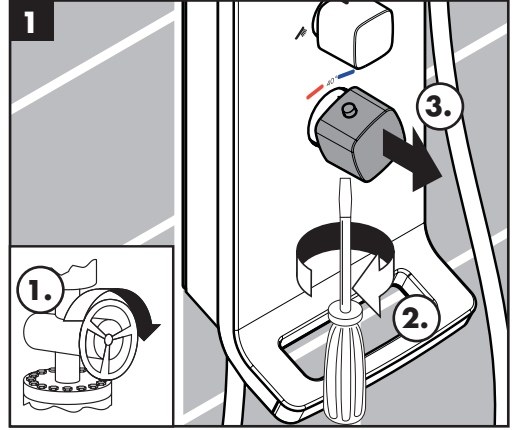
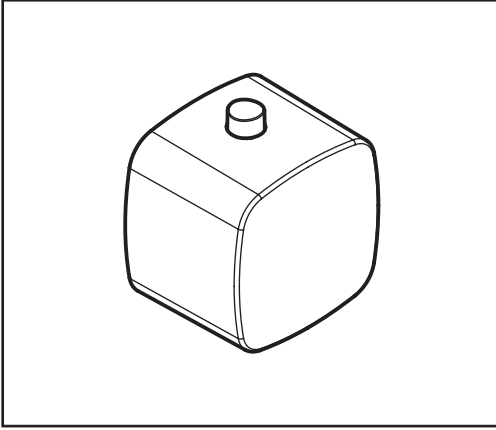

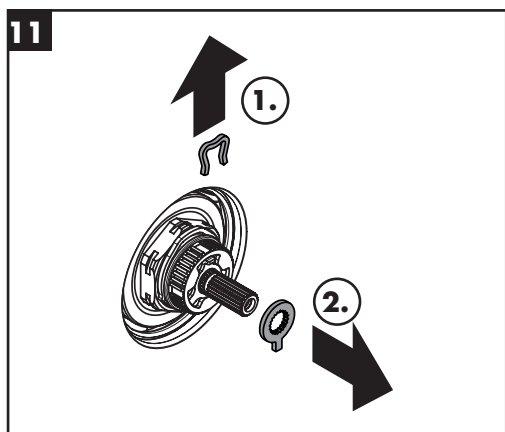
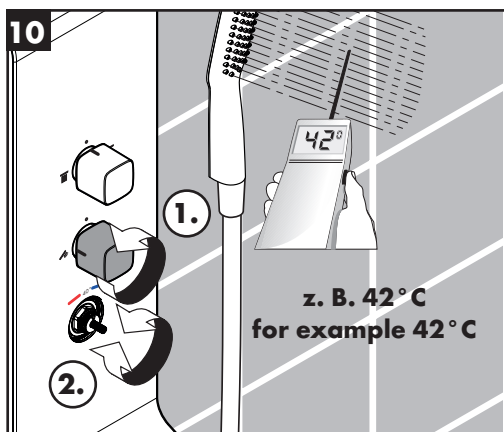
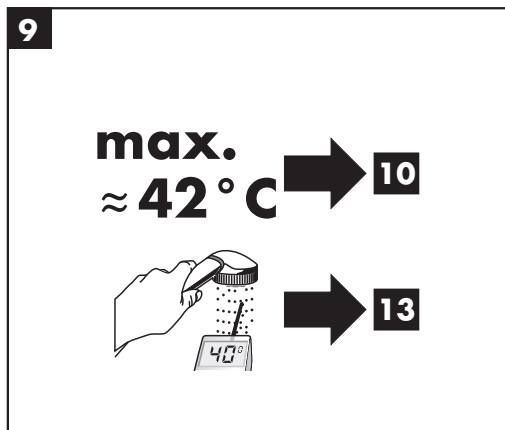
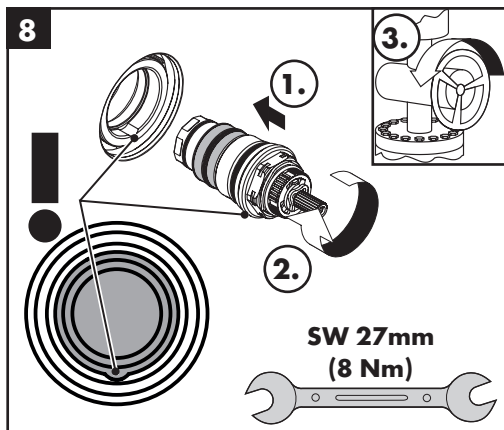
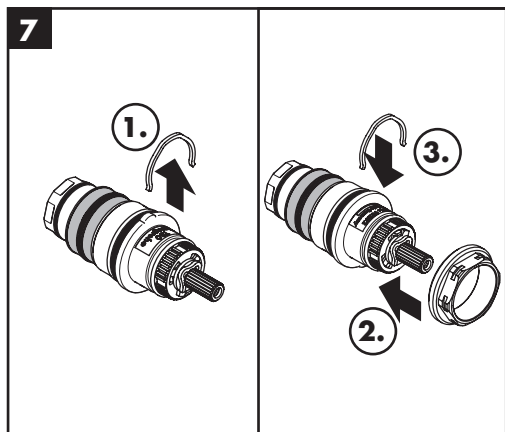
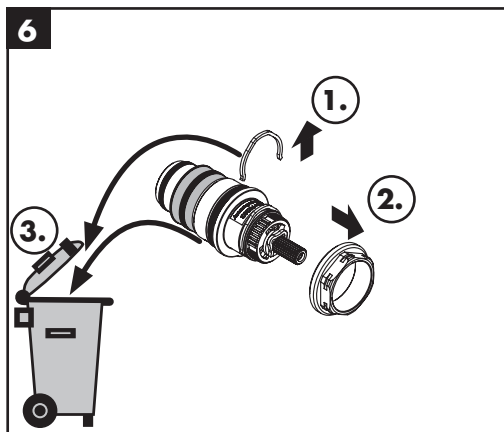

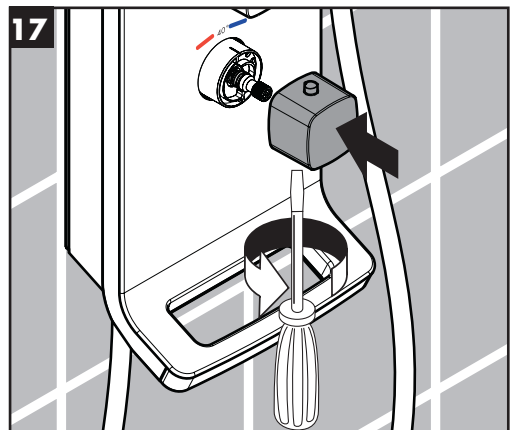
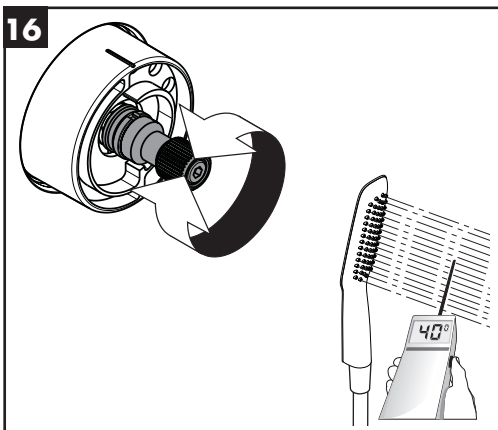
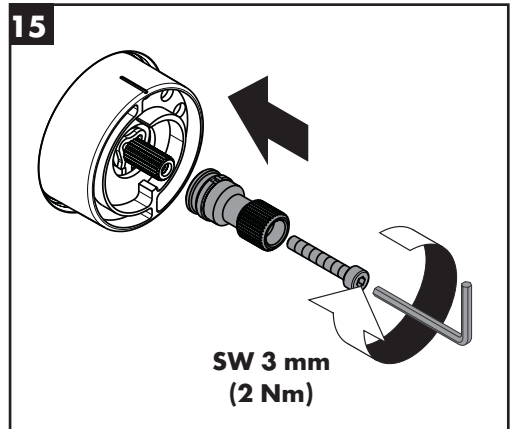
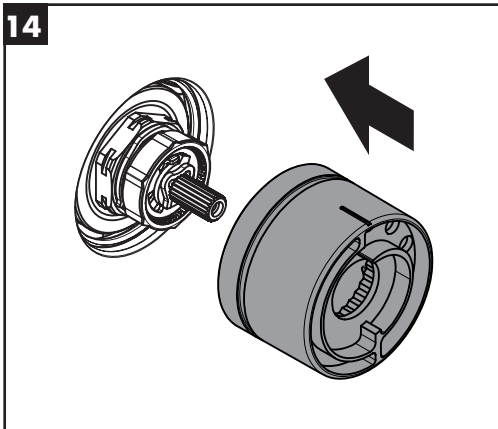
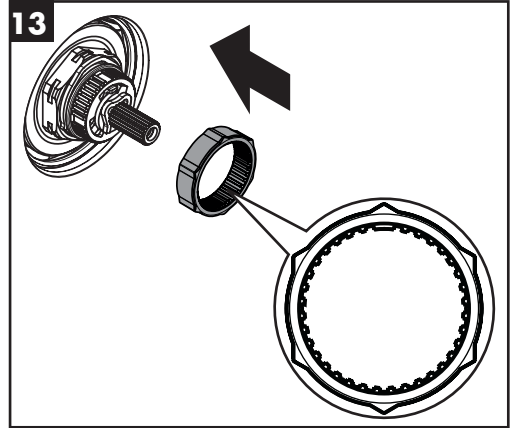
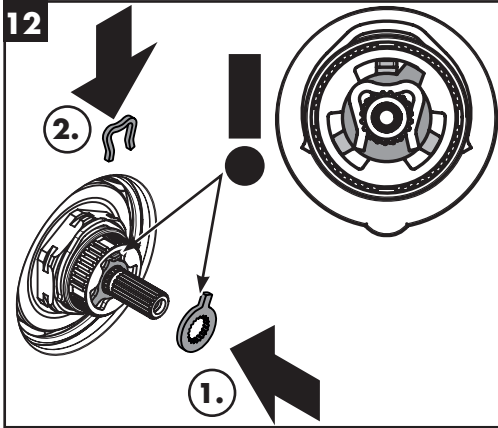



hansgrohe

Hansgrohe · AuestraÙe 5 · 9 · D-77761 Schiltach · Telefon +49 (0) 78 36/51-1282 · Telefax +49 (0) 7836/511440
E-Mail: info@hansgrohe.com · Internet: www.hansgrohe.com

02/2018
9_04751.04